

TONE

REVOLUTION
IN BREWING & EXTRACTION



TOUCH 03

DIGITAL MANUAL

Please download software here



Get in touch with your dealer for
any information about installation.

JANUARY 2024
VERSION 1.4

OPERATING MANUAL

DISCLAIMER

Congratulations on purchasing your new TONE product. The information in this document affects your safety and your legal rights and responsibilities. Read this entire document carefully to ensure proper configuration before use. Failure to read and follow instructions and warnings in this document may result in serious injury to yourself or others, damage to your TONE product, or damage to other objects in the vicinity. This document and all other collateral documents are subject to change at the sole discretion of TONE. For up-to-date product information, visit <http://www.tone-swiss.com> and click on the product page for this product.

By using this product, you hereby signify that you have read this disclaimer and warning carefully and that you understand and agree to abide by the terms and conditions herein. You agree that you are solely responsible for your own conduct while using this product, and for any consequences thereof. You agree to use this product only for purposes that are proper and in accordance with all applicable laws, rules, and regulations, and all terms, precautions, practices, policies and guidelines TONE has made and may make available.

TONE accepts no liability for damage, injury or any legal responsibility incurred directly or indirectly from the use of this product. The user shall observe safe and lawful practices including, but not limited to, those set forth in this document.

Copyright © 2021 by TONE Kaffeemaschinen AG

All rights reserved. No part of this publication may be reproduced, distributed, or transmitted in any form or by any means, including photocopying, recording, or other electronic or mechanical methods, without the prior written permission of the publisher. For permission requests, write to the publisher, addressed at the address below.

TONE Kaffeemaschinen AG
Kasernenstrasse 5
3600 Thun / Switzerland

Manufacturer:
Thuner Kaffeemaschinenfabrik AG
Kasernenstrasse 5
3600 Thun / Switzerland

contact@tone-swiss.com
www.tone-swiss.com

TRADEMARKS

TONE is a trademark of TONE Kaffeemaschinen AG (abbreviated as „TONE“) and its affiliated companies. Names of products, brands, etc.. appearing in this manual are trademarks or registered trademarks of their respective owner companies.



TABLE OF CONTENTS

1. PROPER USE	6
1.1 For your safety	6
1.2 Explanation of safety warnings	6
2. DESCRIPTION OF THE PRODUCT	8
2.1 Purpose of the Product	8
2.2 Contents	8
2.3 Appliance overview	8
2.4 Dimensions	9
3. INITIAL USE	10
3.1 Place of use	10
3.2 Pumping Connection	10
3.3 Electrical Connection	10
3.4 Initial set-up	11
4. PROCESS/WORKFLOW	11
4.1 Brewing	11
4.2 Button Function	11
4.3 Connection	12
4.4 Edit recipes	14
4.4.1 Proven mode	15
4.4.2 Create set	16
4.4.3 Advance mode	16
4.4.4 Freestyle mode	17
4.5 Import /Export recipes	17
4.6 Service	18
5. MAINTENANCE	19
5.1 Cleaning	19
5.2 Daily Cleaning	19
5.3 Descaling	19
5.4 TOUCH O3 Equipment	20
6. FAULT RECTIFICATION	20
7. TECHNICAL DATA	22
8. RECYLING AND DISPOSAL	23
9. WARRANTY	23
10. WIRING DIAGRAM	24
11. WATER SPECIFICATION	25
OPTIONAL FILTER STAND	26
DECLARATION OF CONFORMITY	28

1. PROPER USE

This machine is only intended for the use for which it was basically developed. Any other use shall be considered ill-suited and improper. The manufacturer shall not be considered responsible for any damages caused by improper use. The electric safety to the machine is achieved only when the machine is correctly connected to a grounded electric system.

This fundamental requirement shall be assessed by qualified personnel. Manufacturer and installer shall not be held responsible for any damages caused by the lack or inefficiency of system grounding.

1.1 FOR YOUR SAFETY

Read and follow the instructions in these operating instructions in order to operate this machine safely. Do not carry out any independent modifications or repairs on the device.

The following warning symbols are used in these operating instructions.

1.2 EXPLANATION OF SAFETY WARNINGS



DANGER!

Failure to observe the warning can result in danger to life and limb.



WARNING!

Failure to observe the warning can result in material damage.



CAUTION!

Matters which should be taken into account when using the appliance.



INFORMATION FOR CORRECT DISPOSAL OF THE PRODUCT IN ACCORDANCE WITH EC DIRECTIVE 2012/19/EU

This product must not be disposed of as urban waste at the end of its working life. It must be taken to a special waste collection centre licensed by local authorities or to a dealer providing this service. Separate disposal of the product will avoid possible negative consequences for the environment and for health resulting from inappropriate disposal, and will enable the constituent materials to be recovered, with significant savings in energy and resources.

Separate disposal of the product will avoid possible negative consequences for the environment and for health resulting from inappropriate disposal, and will enable the constituent materials to be recovered, with significant savings in energy and resources.

OBSERVE THE FOLLOWING SAFETY INSTRUCTIONS AT ALL TIMES:

- The appliance is only to be installed in locations where its use and maintenance is restricted to trained personnel.



DANGERS TO CHILDREN AND OTHER PERSONS!

- This appliance can be used by children aged from 8 years and above and persons with reduced physical, sensory or mental capabilities or lack of experience and knowledge if they have been given supervision or instruction concerning use of the appliance in a safe way and understand the hazards involved. Children shall not play with the appliance. Cleaning and user maintenance shall not be made by children without supervision.



DANGER DUE TO FAULTY OPERATION!

Improper use of the appliance can result in damage or injury.

- Do not use the appliance barefoot or when hands / feet are wet.
- Unplug the appliance from the electric system and turn off water supply before carrying out any cleaning and ordinary maintenance.
- Do not put the appliance under a jet of water, nor plunge it into water to clean it.
- Do not leave the appliance turned-on and unattended for long periods (e.g. 1 day)

- In order to ensure the efficiency and correct functioning of the appliance, it is necessary to follow the instructions provided by the manufacturer and to carry out its ordinary maintenance.

- The appliance shall be installed so that the highest surface is at least 1 metre high.

- The appliance shall be placed on a level horizontal surface to ensure a safe use.

- The temperature range of the environment surrounding the appliance shall be included between 5°C and 30°C. In case the appliance is temporarily placed in an environment where the temperature is below 0°C, contact a local Technical Service authorized by the manufacturer.

- The machine shall be placed on a surface guaranteeing secure support.

- Ideally the appliance is bolted onto the working surface using a pair of slotted countersunk screws (M8, stainless).

- The machine must be connected exclusively to an appropriate cold drinking water source, in compliance with national norms and rules. The pressure of the incoming water must be between 0.15-0.3 MPa. If this does not meet, install a pressure reducer / regulator according to the requirements.

- A shut-on tap must be installed between machine water hose and water system to block water flow in case of necessity.

- When installing the appliance, use exclusively the current hose-set provided with the appliance itself.

- In case of appliance breakdown and/or malfunctioning, turn the main switch OFF and refrain from trying to repair it. Then contact a local Technical Service that has been authorized by the manufacturer.



WARNING DUE TO UNAUTHORISED REPAIR!
Faulty repairs can result in damage to the appliance.

- Repairs should be carried out only by authorised customer service centres.

- If you cannot correct a fault with the aid of the steps described in these operating instructions, please refer to your authorised dealer.

- The electric safety of the machine is achieved only when the machine is correctly connected to a grounded electric system.

- The user shall arrange electric, water and draining systems in a suitable position to allow correct machine installation.



WARNING BEFORE SERVICING OR OPENING

this device make sure the brewer is disconnected from power by pulling its plug. The service technician has to see

the pulled plug during the whole service operation.

- The installer cannot modify the existing system built by the user.

- If the electric supply plug is damaged, it must be replaced by another plug provided by the manufacturer or by its Technical Service.

- For good machine functioning and maintenance, it might be necessary to install a water softener in order to avoid scale formation. This must be evaluated by the installer and the user shall leave a space for the correct installation of a water softener, following the instructions contained in its manual.



Do not use water jet devices in the area where TOUCH 03 is installed!



Do NOT tilt TOUCH 03 during operation! Max. tilt angle < 5°.



Only to be operated by trained personnel!

2. DESCRIPTION OF THE PRODUCT

2.1 Purpose of the Product

This machine shall be destined exclusively to the use it has been expressly designed for. Any other use shall be considered illsuited and improper.

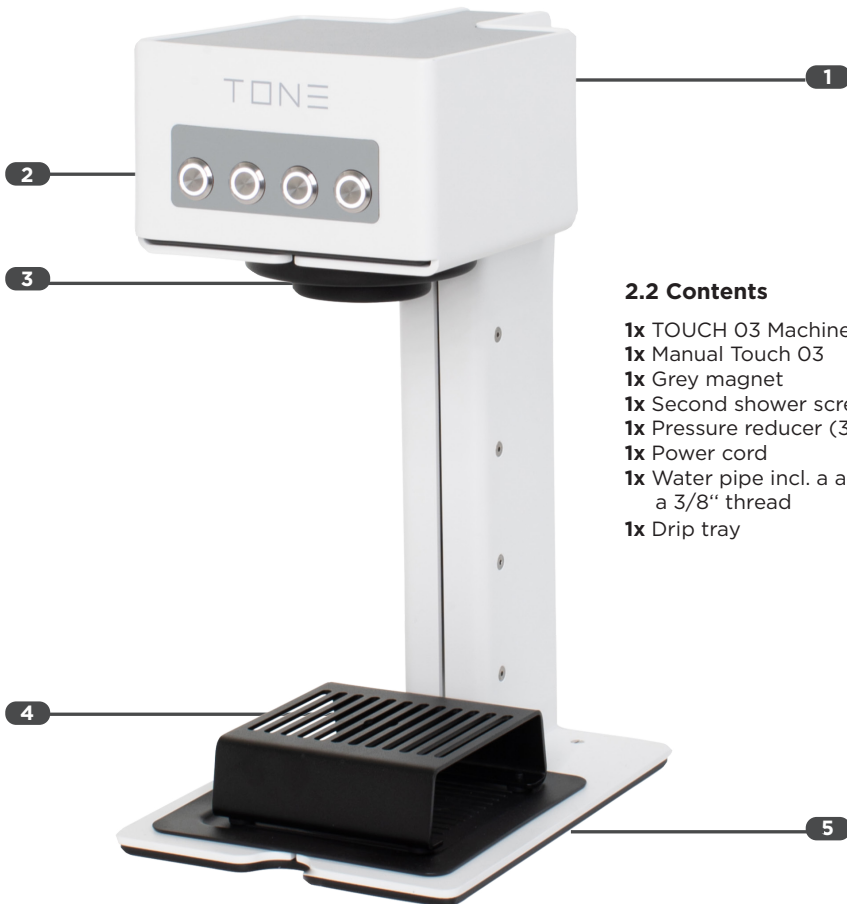

2.2 Contents

- 1x TOUCH O3 Machine
- 1x Manual Touch O3
- 1x Grey magnet
- 1x Second shower screen
- 1x Pressure reducer (3bar)
- 1x Power cord
- 1x Water pipe incl. a adapter with a 3/8" thread
- 1x Drip tray

2.3 APPLIANCE OVERVIEW

- 01 Power switch (on back side)
- 02 Four programmable buttons
- 03 Spray head

- 04 stand for smaller brewing vessels (optional)
- 05 Drip tray
- 06 Brew basket holder (optional) (Image missing)



CAUTION
Improper electrical installation will damage electronic components. Damage caused by incorrect electrical connections is not covered by warranty.



CAUTION
Power to brewer must be OFF before proceeding with plumbing installation.

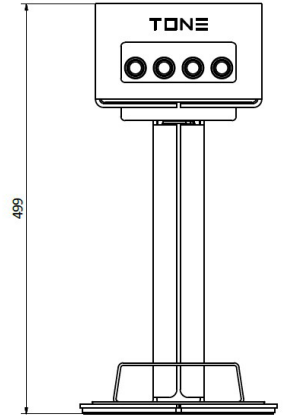

Cold Water | Softener

Ethernet connection cable

Powercord
P | N | GR

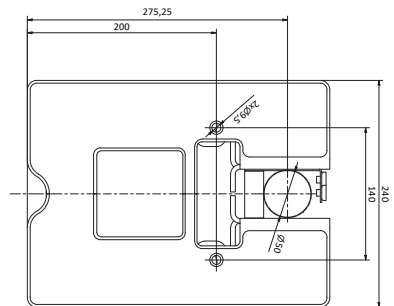
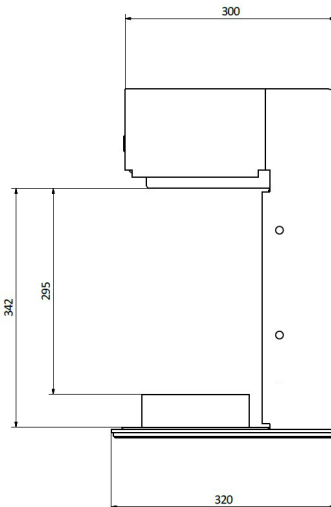

3. INITIAL USE

3.1 PLACE OF USE

Brewer should be installed only inside and in a dry environment. Brewer should be installed on a secure, level, surface capable of fully supporting the weight of the brewer, including the water retained in the brewer, and any fully loaded dispenser(s) that may be placed on the brewer.

- A potable water line (cold water) capable of consistently supplying the required minimum flow rate within the noted pressure range is required at the install location.
- A grounded electrical connection to a circuit that meets the electrical specifications of the brewer and is protected by the appropriate size and type of breaker is required. See the supply cable specification in chapter 3.3.



CAUTION

Power to brewer must be off before proceeding with plumbing installation.



CAUTION

Improper electrical installation will damage electronic components. Damage caused by incorrect electrical connections is not covered by warranty.

3.2 PLUMBING CONNECTION

- The brewer must be rinsed after being connected to the water supply line. Remaining air in the system will be removed. Otherwise it may lead to malfunctions and noise in the housing. Follow instructions in section Button functions.
- The pressure of the water line must be within 1.5 bar – 3 bar.
- The installation of a water softening filter system is mandatory for the use of TONE

equipment. Any violation of this regulation will lead to a complete loss of any warranty on the complete system.

- The brewer has a descaling tracking function available. Follow the instructions on page 19.
- Equipment is to be installed with adequate backflow protection to comply with applicable federal, state, and local codes (USA).

3.3 ELECTRICAL CONNECTION



WARNING

The brewer must be disconnected from the power source until specified in INITIAL SET-UP.



CAUTION

Improper electrical installation will damage electronic components. Damage caused by incorrect electrical connections is not covered by warranty.

- An electrician must provide electrical service as specified in conformance with all local, state and federal electrical codes.
- Recommended backup fuse: 16A
- If the supply cable is damaged, it must be replaced by the manufacturer, its service agent or similarly qualified person in order to avoid a hazard
- The electrical ratings can be found on the type plate which you will find on the device.
- Use a voltmeter to check the voltage and color coding of each conductor at the electrical source.
- Ensure power switch on rear of brewer is in the off position. Connect brewer to power source and verify voltage at terminal block. Replace rear panel and top cover. If plumbing has been hooked up, brewer is ready for Initial Set-Up. If not, disconnect brewer from power source.



WARNING

Electrical connections must be made as specified above. Failure to follow these instructions can result in personal injury, property or equipment damage.



WARNING

Before servicing or opening this device make sure the brewer is disconnected from power by pulling its plug. The service technician has

to see the pulled plug during the whole service operation.

This device must be connected to a line system impedance $Z_{sys} \leq 0.082 + j0.051 \Omega$

Symbol explanation:

I = ON

O = OFF

Consult the supply authority before connecting.

3.4 INITIAL SET-UP

- Remove the grey cover from the housing.
- Connect the blue water house with the Touch O3 and your water supply. (Note: The TONE Touch O3 needs to be run with filtered water)
- The water pressure should be between 0.15 and maximum 0.3 MPa (the flow of the machine is calibrated at the factory with 0.23 MPa). A pressure reducer is supplied with the machine to ensure that no more than 0.3 MPa of water pressure enters the machine.
- To prevent the water from flowing back into the drinking water system, a check valve is supplied with the Touch O3. This must be installed in the blue water hose. (check the correct flow direction)
- The delivered connection adapter from TONE has a 3/8 inch thread.
- Plug the machine into the 230 V socket.
- Build up a connection with a laptop or

tablet to your Touch O3. Connection by ethernet cable to your laptop or connection by ethernet cable to a lan switch or connection over wifi with the IO-GEAR device. Check chapter 4.3 Connecting.

- Install the TONE beverage manager on your device (IOs, Mac, Windows 10 or Android).
- Rinse the machine by pushing the buttons 1 & 2 and the main switch (the two buttons will shine up blue and cold water will rinse through the machine until you switch off the machine). This will help to get rid of the air inside of the brewer system.
- Calibrate the flow of the machine to its new home. See section 4.6

4. PROCESS/WORKFLOW

4.1 BREWING

Equip a brewing vessel of your choice with a filter and fill in an appropriate amount of brewing ingredients.

Place the brewing vessel with loaded filter underneath ingredients. Decide whether you need the optional stand or brew basket holder and select the desired recipe by pushing the corresponding button. As soon as the program is running the button starts to blink. Be aware that the water flow may be interrupted during the brewing process once or several times. Wait until the recipe is processed completely (button stops to blink).

Remove the brewing vessel from the appliance and the TONE Touch O3 is ready for use again immediately. The program can be aborted by pushing the chosen button again during process.

There are four factory standard recipes installed on every Touch O3 (from left to right):

- | | | |
|----------|---------------|---------------|
| 1 | Volume: 300ml | Taste: mild |
| 2 | Volume: 300ml | Taste: medium |
| 3 | Volume: 300ml | Taste: bold |
| 4 | Volume: 300ml | Taste: xbold |



The recipes can be exchanged or modified by connecting your pc or tablet to the Touch O3. See chapter 4.4 to learn how to create a recipe.

4.2 BUTTON FUNCTION

Recipe selection:

Button 1 – 4 (from left to right)

Descaling:

Push and hold Button 1 while switching the main switch ON

Rinsing:

Push and hold button 1 & 2 while switching the main switch ON. Stop the rinsing by switching the main switch OFF

- Rinse the device after a long-lasting down time or when there may be air inside the system.

- Before air transport or exposure to temperatures below 4°C all remaining water inside the brewer has to be removed. Disconnect the water supply and start the rinsing procedure.



IT IS NOT ALLOWED TO BLOW OUT THE MACHINE IN ANY WAY!

No blowing out with the mouth, no compressed air, no blowing out with the

syringe, etc. This will destroy the sensitive flow meter!



Buttons 1 & 4 light up blue

1. Check if the NTC sensor cable (white) is disconnected.
2. Please, contact your dealer.



Button 1 & 3 & 4 light up blue

- E-fast disconnected (violet cable)
- Both solid state relay . disconnected (missing signal)
- Heating fuse defective
- Cables on top of the heater are disconnected.

1. If you have the firmware 2.6.0 or 2.6.1 on your Touch O3 please do an upgrade to the latest firmware version.
2. Please, contact your dealer.



Buttons 3 & 4 light up blue

No flow / water supply interrupted

1. Check your water supply / open the main valve
2. Rinse the machine with approx. 1L by pushing button 1/2 + main switch
3. Descale the machine (check manual)
4. Please, contact your dealer.



Buttons 2 & 4 light up blue

- Proportional valve is leaking
1. Rinse the machine with approx. 1L by pushing button 1/2 + main switch
 2. Please, contact your dealer.



Buttons 2 & 3 & 4 light up blue

- Brewer overheated / error on heating element / defective thermostat / Flow problem not resolved / missing signal from solid state relay.

1. Switch the brewer OFF and let it cool down.
2. Do a reboot of the machine by pushing the buttons 1/3/4 and main switch together. Afterwards the buttons shine up blue. Switch off / on the machine again.
3. Please, contact your dealer.

For more precise informations go to page 20. Otherwise please contact your dealer.

Trouble shooting

If vibrating noises are heard from the machine housing, there could be air in the system. This can be the case in particular if the water supply line has been interrupted. In order to remedy the fault, the device must be rinsed. Follow the instructions in the

section Button Functions.

In case of any other issues, please contact your dealer.

4.3 CONNECTING

OPTION 1 A

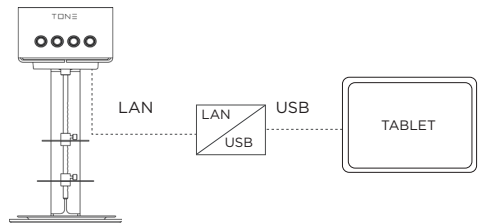

Direct Connection

(direct or via a LAN-2-USB Converter)

- connect the TONE to the tablet / pc
- or
- connect the TONE via the LAN-2-USB converter to your tablet / pc
- only one TONE can be connected to the tablet / pc

OPTION 1B

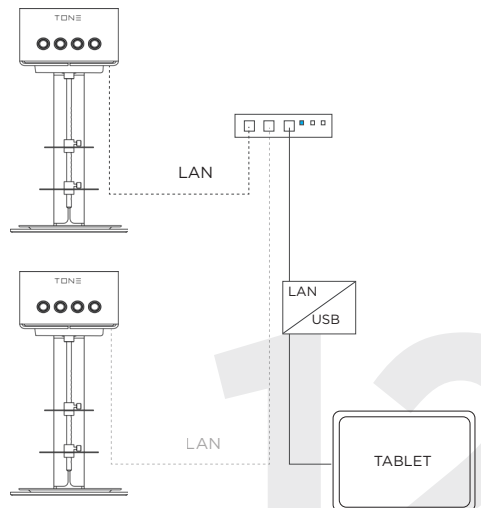

LAN-Switch / LAN-router

- connect the TONE to the LAN switch
- connect the LAN switch to the tablet / pc (direct or via LAN-2-USB converter)
- you can connect one or more TONE to the tablet / pc

NOTE:

The ethernet port configuration on your tablet / pc should be as follow:

1. connect the cable direct to your device or via the LAN-2-USB converter
2. Open the ethernet properties
Settings - Network and Internet - Ethernet - properties
3. Select automatic mode (dhcp) at the ip-assignment

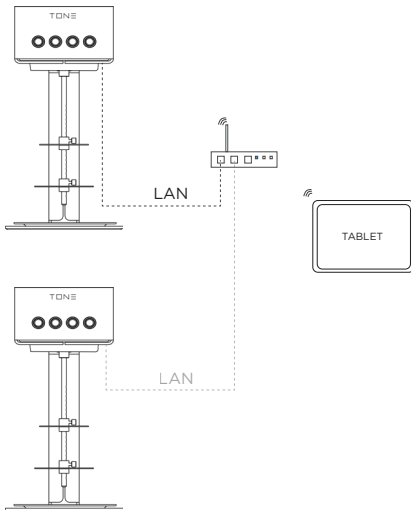
OPTION 2A**Wifi-Router**

- connect the TONE to the wifi router
- connect the tablet / pc to the wifi router
- you can connect one or more TONE to the tablet / pc

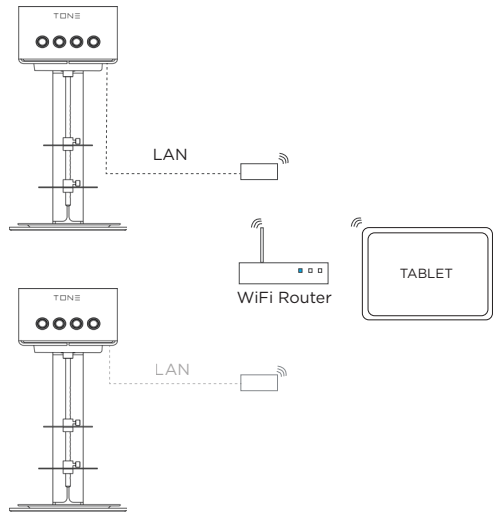
OPTION 2B**Ethernet-2-Wifi-Converter (IO-GEAR)**

For each TONE you need an Ethernet-2-Wifi-Converter

- Consider the specific manual / video for the set-up on www.tone-swiss.com



MAKE SURE THAT YOU DISABLE "LIMIT THE TRACKING OF YOUR IP-ADDRESS" ON ANY DEVICE YOUR TONE BEVERAGE MANAGER IS INSTALLED. IF THIS

BUTTON IS NOT SWITCHED-OFF YOU MIGHT NOT SEE THE BREWER IN THE TONE BEVERAGE MANAGER.

4.4 EDIT RECIPES

Connect your TONE Touch03 brewer with the TONE tablet computer as described in the previous section. Once the installation is complete, switch your TONE Touch 03 ON and it will appear in the list of available TONE equipment as soon you select the tab Touch 03. The factory pre-set name will be ToneTouch03_XXXXX (XXXXX=serial number). This

can be customised later (s. Service tab).

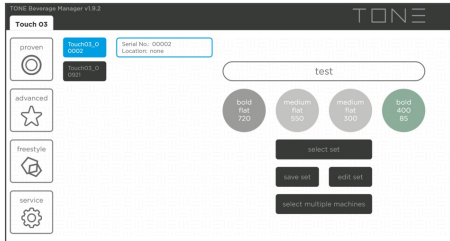

Click on your device in the list and the standard configuration of the recipe selection buttons will be displayed. You can either change this configuration by clicking each button individually and chose recipes from the list which will be explained later. Or you can choose a whole set of recipes that you can put together (check page No. 16)

Please remark that your adaptations are made directly on the device. There is no need for a transfer command or a click on a confirmation checkbox here.

4.4.1 PROVEN MODE

The proven tab provides a tool for a quick and successful recipe creation. There are four pre-set options for coffee and three for tea, which will result in different flavour intensities of the beverage.

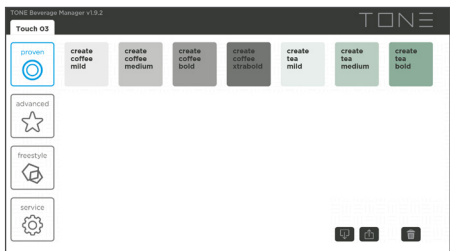

For the coffee recipes, the brewing temperature and the pulsation of the water flow is pre-defined, based on the experience of TONE coffee experts. You can simply adjust the amount of water (Insert the

desired value using the keyboard or the arrow keys.) and choose between cone and flat filters. Make sure you have installed the correct shower screen insert for each filter type. For the cones you need to install the screen with 5 holes, for the flat filter the screen with 18 holes.

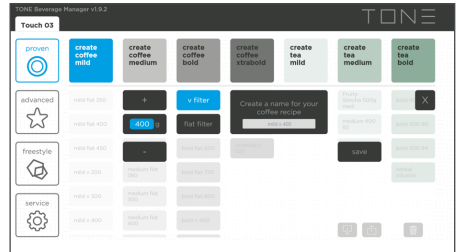

Enter the desired recipe name and click the save button. Your recipe will appear on the recipe list.

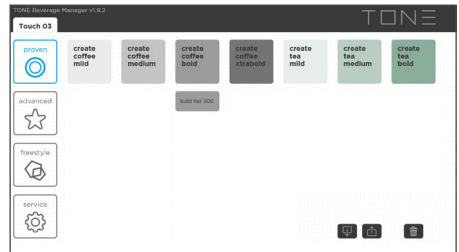

If you do not enter a specific name, the program will give you a name for the recipe, which includes the strength of the coffee, the amount of water, and the type of filter used.

The settings of the tea recipes are slightly different. Choose the water temperature considering the type of tea which shall be prepared. The different tea options differ regarding the number of pulses and their characteristics.

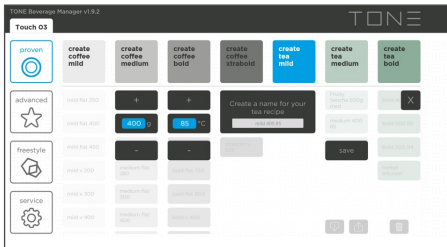

The name of a tea recipe will tell you the strength of the flavour, the amount of water and the brewing temperature. If a recipe is no longer needed, you can delete it in this window by clicking on the trash bin and selecting the recipe(s) you no longer need.

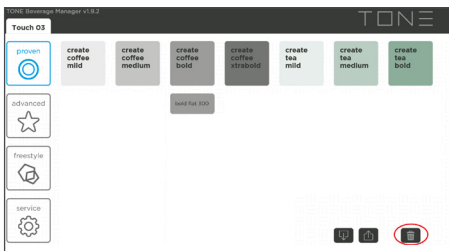

4.4.2 CREATING SETS

You can compose a set of recipes by clicking on each button of the four square buttons and choosing a recipe from the list.

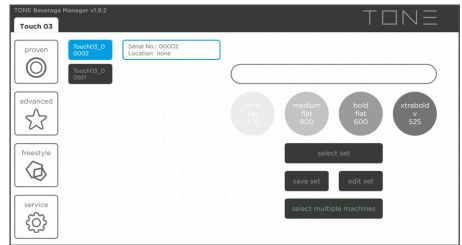
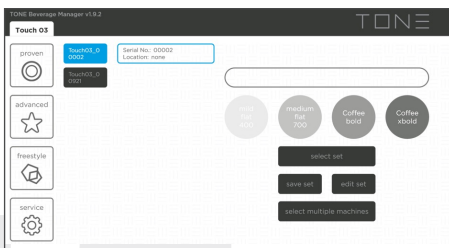

Once you have made your selection of recipes, press “save set”, choose a meaningful name and select the desired category. Press then save again.



Then press “select set” and select the desired set in the corresponding category. If you press “edit set” you can change one specific set or delete it if no more needed.

4.4.3 ADVANCED

The Advanced tab provides you a very intuitive and comprehensive tool for the creation of new recipes. You can set the temperature of each extraction phase (bloom, turbulence, development) and define the characteristics of the water pulses (quantity, flow ratio, duration, interval).



First of all, you should set the water target which you would like to produce. This value will not be exceeded. Varying the bloom or the turbulence phase will adapt the development phase automatically. The development phase itself is self-adjusting between duration and flow ratio of its pulses.

Second, you can define how much coffee you need for your recipe by specifying the brew ratio. The amount of coffee is indicated in small letters below. In the same place, you will also see a recommendation of how much water is needed for the blooming phase (this can be transferred to the blooming column if required).

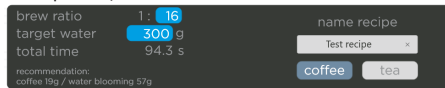

When you have finished your recipe, you can save it by giving the recipe the name you want, selecting the right category and clicking “save recipe”. It will then appear in the selection lists when you press the desired key on your selected machine (Touch03) and select it from the advanced chapter. There is also the possibility to change existing advanced recipes by clicking “edit recipe”.

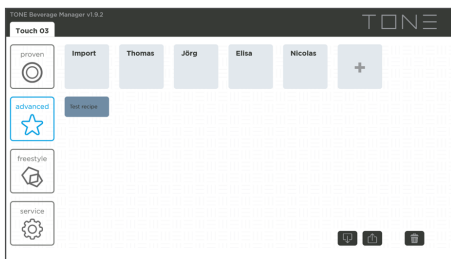

A new category can be done by pressing the + button in the advanced recipe list.

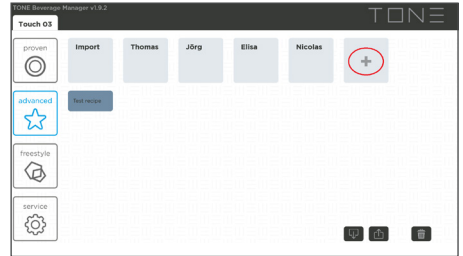

4.4.4 FREESTYLE

The freestyle chapter provides a way to create a recipe entirely without restrictions or frameworks.

As a first step, you can define the number of pulses (maximum 20) using the + and - keys. Further you can define the parameters per pulse individually. In the upper part you can see the total amount of water and the total time of the recipe.

After assigning a specific name and selecting Coffee or Tea, you can save the recipe with the „save recipe“ key. Again, it is also possible to modify existing recipes with the „edit recipe“ key.

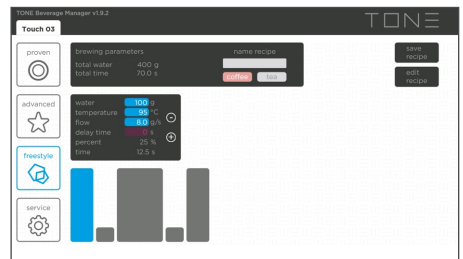

4.5 IMPORT / EXPORT FUNCTION

If you want to use an existing recipe or send a recipe you have created to someone, you can use the import / export function. Open the desired tab (proven, advanced or freestyle). Press the edit recipe button. Now you can decide whether you want to import a new recipe or export an existing one.



Import

Select the button if you want to import a new recipe (sent to you from somewhere else) and retrieve the file from where you saved it on your device.



Export

Select the button if you want to export a created recipe. The button will turn blue (see pic. 1) and you can now select all the recipes you want to export. Once you have done this, press the button again (the button will now have a green checkmark, see pic. 2) and select your desired memory location.



Pic 1



Pic 2

4.6 SERVICE

The Service tab provides possibilities to customise the brewer identification and the calibration. And you can also check all important parameters. Clicking on the service tab will automatically open a login pop-up window. Entering the password “TONEservice” enables all available options. Select one of the brewers listed in the left column.

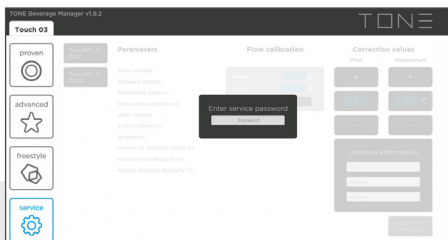

In the field “Location information” you can enter a meaningful description of your brewer and its location.

Location information

In case your brewer should extract more or less water than intended you can tweak the flow rate by setting a value below 1 in case you want to reduce the amount of water or a value above 1 if you want to increase the amount of water. This is a very sensitive tool an can only be adjusted in permille steps.

Flow calibration

target: g

result: g

Correction values

Flow	Temperature
<input style="width: 40px; height: 30px; border: 1px solid #ccc; background-color: #333; color: white;" type="button" value="+"/>	<input style="width: 40px; height: 30px; border: 1px solid #ccc; background-color: #333; color: white;" type="button" value="+"/>
<input style="width: 40px; height: 30px; border: 1px solid #ccc; background-color: #007bff; color: white;" type="text" value="1.034"/>	<input style="width: 40px; height: 30px; border: 1px solid #ccc; background-color: #007bff; color: white;" type="text" value="0"/> °C
<input style="width: 40px; height: 30px; border: 1px solid #ccc; background-color: #333; color: white;" type="button" value="-"/>	<input style="width: 40px; height: 30px; border: 1px solid #ccc; background-color: #333; color: white;" type="button" value="-"/>

For the exact calculation of the flow correction you can use the calculator. Enter the desired quantity (target) and the previously measured quantity in the “result” field. Then press the “calibrate” button to transfer the calculated correction to the “Flow” field. This correction is always added to or subtracted from the existing correction.

In case your extraction temperature doesn't fit to the set values of the recipes (e.g. when there is very cold water supply) you can adjust the temperature by clicking “+” or “-“. The maximum values are +5/-5°C.

Keep in mind that the maximum possible temperature of a recipe is limited at 97°C. Theoretically you could then achieve a temperature of 102°C. The heating system will then produce steam instead of water, which needs to be prevented in order to achieve good brewing results.

Please also remark that the boiling point of water drops with increasing altitude (ffi -1°C/300m).

With the “firmware update” button you can easily update the machine. Press the button, select the appropriate “file” on your device and upload it. (If necessary, check with your authorized dealer if a new file is available).

5. MAINTENANCE

5.1 CLEANING



DANGER due to improper cleaning!

Improper cleaning can result in damage to the appliance or personal injury.

- To guarantee proper functionality of TONE equipment it is necessary to clean the device on each day.
- To clean the surface of TONE equipment, it is recommended to use a damp cloth soaked in a 1% soda solution (Na_2CO_3).
- Never immerse the appliance itself, the power supply cable or plug in water.
- Never pull the plug out of the socket by the cable, always grasp the plug.
- Never attempt to touch or pick up and electrical appliance if it has fallen into water. In this case, disconnect the plug from the socket immediately.
- Check the appliance and cable regularly for damage.



DANGER due to unauthorised repair!

Repairs should be carried out only by authorised customer service centres.

- If you cannot correct a fault with the aid

of the steps described in these operating instructions, please refer to your authorised dealer.

5.2 DAILY CLEANING

- Do not use water jet device to clean the TONE equipment.
 - Do not use abrasive means to clean the TONE equipment.
 - Check and clean the showerhead daily. All holes of the spray head must always remain open
- NOTE** - Any remains on the showerhead may influence the water flow and impact your coffee brewing.

5.3 DESCALING

To guarantee proper functionality of TONE equipment, it is necessary to descale the device. The descaling of the TONE Touch 03 brewing system is mandatory as soon the chasing light is appearing or at least once a month. Any violation of this regulation will lead to a loss of any warranty on the complete system.

The demand of a descaling process is indicated on the recipe buttons by a blue chasing light: -> <- ->.



Blue chasing light (**Button 1-4**) after switching the brewer ON and after finishing a recipe

- Descaling necessary

This signal is shown after switching the machine ON and at the end of every extraction.

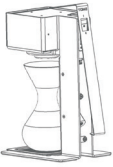
**STEP 1**

Remove the cover from the TONE Touch O3.

**STEP 2**

Before the descaling process is started, a vessel with a minimum volume of one liter must be placed underneath the shower.

STEP 3

Remove the lid from the descaling agent container.

**STEP 4**

Screw the descaling agent container into the descaling valve. If the bottle can only be screwed in with great effort, apply a little food grade grease to the thread.

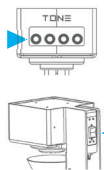
**STEP 5**

Push and hold button one while switching the machine ON again.

**STEP 6**

Allow the decalcification recipe (duration approx. 12 min) to run through completely. As soon as the descaling is completed, button one shines constantly blue.

STEP 7

Remove the descaling agent container and restart the machine.

**STEP 8**

Flush the whole system by extracting at least 300 gramm of hot water.

STEP 9

The TONE Touch O3 is then ready again for brewing excellent coffee.



Scan the QR Code and take a look at the How-to Video.

5.4 TOUCH O3 EQUIPMENT

- stand for smaller brewing vessels (see picture on page No. 08)
- filter stand for variable brew distances (see picture on page No. 8 or the instructions on PAGE NO. 24)
- TONE Green Clean (descaling liquid): one design carton includes 12 green clean bottles x 29 ml - suitable for one year cleaning

6. FAULT RECTIFICATION

PROBLEM	SOLUTION
Overheating (Buttons 1 & 4 light up blue)	<ol style="list-style-type: none"> 1. Check if the NTC sensor cable (white) is disconnected. 2. Please, contact your dealer.

<p>No flow / water supply interrupted</p> <p>Buttons 3 & 4 light up blue</p>	<ol style="list-style-type: none"> 1. Check your water supply / open the main valve 2. Rinse the machine with approx. 1L by pushing button 1/2 + main switch 3. Descal the machine 4. Please, contact your dealer.
<p>Buttons 2 & 4 light up blue -> Proportional valve is leaking</p>	<ol style="list-style-type: none"> 1. Rinse the machine with approx. 1L by pushing button 1/2 + main switch 2. Please, contact your dealer.
<p>Buttons 2 & 3 & 4 light up blue</p> <p>Brewer overheated / error on heating element / defective thermostat / Flow problem not resolved / missing signal from solid state relay.</p>	<ol style="list-style-type: none"> 1. Switch the brewer OFF and let it cool down. 2. Rinse the machine with approx. 1L by pushing button 1/2 main switch together. 3. Please, contact your dealer.
<p>The machine is heavy sputtering at the beginning of each pulse.</p>	<ol style="list-style-type: none"> 1. Please, contact your dealer.

<p>No recipes visible on the keys (TONE-App)</p>	<ol style="list-style-type: none"> 1. Check if the number of the machine on the left side is marked 2. Do a reboot of the machine by pushing 1/3/4 and main switch together 3. Update the machine with the actual firmware 4. Please, contact your dealer.
<p>Dripping from the machine even when the machine is switched off</p>	<ol style="list-style-type: none"> 1. Rinse the machine with approx. 1L by pushing button 1/2 and mainswitch together 2. Descal the machine (check manual) 3. Please, contact your dealer.
<p>After switching on, the machine let the water flow though without pushing any Button before or there is no water coming through at all. This means the proportional valve does not open or close at all. (for example during a first installation of the machine).</p>	<ol style="list-style-type: none"> 1. Push the buttons 1+3 and main switch together. This will cause a repeated opening and closing of the proportional valve including a subsequent flushing for 10 sec. This might help to get rid of some lime scale etc. (This action can only be performed if firmware 2.7.0 is called on the machine). 2. Start again a recipe 3. Please, contact your dealer.



PROBLEM	TIP
When starting a recipe, no water comes out of the machine (the selected button keeps blinking)	<ol style="list-style-type: none"> 1. Check the fuse of the heating element 2. Check if during the run of a recipe the LED of both solid state relays are blinking. 3. Update the firmware 4. Please, contact your dealer.
The machine is not visible in the TONE App (Connection is done by ethernet cable)	<ol style="list-style-type: none"> 1. Check the regulations of your firewall for the TONE app. 2. Select the automatic mode in the ethernet properties. 3. Switch off/ on the machine and the TONE App 4. Check if the machine number is visible in the TONE App 5. Please, contact your dealer.
The machine is not visible in the TONE App (Connection is done over wifi with the IO-GEAR device)	Check the setup of the IO-GEAR device regarding the manual "IO-GEAR Setup" (check video and document on www.tone-swiss.com)

EEC CONFORMITY DECLARATION ACT 2006/42/EC

The undersigned: TONE Kaffeemaschinen AG with premises at: Kasernenstraße 5, 3600 Thun, Switzerland

Declares that: The coffee machine has been projected and manufactured in conformity with Directive 2006/42/EC and relevant national law, in accordance with the following norm for conformity evaluation: UNI 9887, ISPSSEL rev. 95.

7. TECHNICAL DATA

Type	TOUCH 03
Designation	Beverage maker
Dimensions in mm <small>(w x h x d)</small>	242 x 505 x 324
Weight	22 kg
Boilervolume	boilerless
Maximal waterflow	8g/sek
Required water pressure	0.15 - 0.3 MPa / 1.5 - 3 Bar
Maximal water pressure	1.0 MPa / 10bar
Noise level	< 50 dB

The electrical ratings can be found on the type plate which you will find on the device.

8. RECYCLING AND DISPOSAL

Instructions for the disposal of old products.

The WEEE Directive (Waste from electrical and electronic equipment; 2002/96/EG) was passed for the protection of human health and the environment, in order to ensure that old products are disposed of so as to make use of the best possible recovery and technical recycling possibilities.

Your product has been developed and manufactured from high-quality materials and components, which can be largely recovered and recycled. Do not dispose of the product as normal domestic waste. Please find your local collection points for electrical and electronic waste products, which are marked with this symbol:

Please make use of one of the following disposal possibilities:



1. Dispose of the complete product (including the cable, plug and accessories) at the relevant WEEE collection point.

2. If you are buying a replacement product, you can

return the old appliance to the dealer. Under the WEEE Directive, retailers are obliged to take back such old appliances.

9. WARRANTY NOTE

TONE Kaffeemaschinen AG warrants equipment manufactured by it for 1 year parts and labor. Accessories and Dispensers 1 Year parts only. Electronic Circuit and

Control Boards- 2 years parts, 1 year labor. Equipment manufactured by others and distributed by TONE - Please see original equipment manufacturers warranty, TONE Kaffeemaschinen AG will follow.

These warranty periods run from the date of sale TONE warrants that the equipment manufactured by it will be commercially free of defects in material and workmanship existing at the time of manufacture and appearing within the applicable warranty period. This warranty does not apply to any equipment, component or part that was not manufactured by TONE or that, in TONE's judgment, has been affected by misuse, neglect, alteration, improper installation or operation, relocation or reinstallation, improper maintenance or repair, incorrect voltage applied to the unit at any time, damage or casualty. This warranty does not apply to any equipment failures related to poor water quality, excessive lime and chlorine and non periodic cleaning and descaling. Warranty is null and void if muriatic or any other form of hydrochloric acid is used for cleaning or deliming. In addition, this warranty does not apply to replacement of items subject to normal use including but not limited to user replaceable parts such as faucet seat cups, sight gauge tubes, washers, o-rings, tubing, seals and gaskets.

This warranty is conditioned on the Buyer

1) giving TONE Kaffeemaschinen AG prompt notice of any claim to be made under this warranty by telephone at +41 52 620 06 06 or by mail to service@tone-swiss.com;

2) if requested by TONE Kaffeemaschinen AG, shipping the defective equipment prepaid to an authorized TONE Kaffeemaschinen AG service location; and

3) receiving prior authorization from TONE Kaffeemaschinen AG that the defective equipment is under warranty.

THE FOREGOING WARRANTY IS EXCLUSIVE AND IS IN LIEU OF ANY OTHER WARRANTY, WRITTEN OR ORAL, EXPRESS OR IMPLIED, INCLUDING, BUT NOT LIMITED TO, ANY IMPLIED WARRANTY OF EITHER

MERCHANTABILITY OR FITNESS FOR A PARTICULAR PURPOSE.

The agents, dealers or employees of TONE Kaffeemaschinen AG are not authorized to make modifications to this warranty or to make additional warranties that are binding on TONE Kaffeemaschinen AG. Accordingly, statements by such individuals, whether oral or written, do not constitute warranties and should not be relied upon.

If TONE Kaffeemaschinen AG determines in its sole discretion that the equipment does not conform to the warranty, TONE Kaffeemaschinen AG, at its exclusive option while the equipment is under warranty, shall either

1) provide at no charge replacement parts and/or labor (during the applicable parts and labor warranty periods specified above) to repair the defective

components, provided that this repair is done by a TONE Kaffeemaschinen AG Authorized Service Representative; or

2) shall replace the equipment or refund the purchase price for the equipment.

THE BUYER'S REMEDY AGAINST TONE KAFFEEMASCHINEN AG FOR THE BREACH OF ANY OBLIGATION ARISING OUT OF THE SALE OF THIS EQUIPMENT, WHETHER DERIVED FROM WARRANTY OR OTHERWISE, SHALL BE LIMITED, AT NEWCO'S SOLE OPTION AS SPECIFIED HEREIN, TO REPAIR, REPLACEMENT OR REFUND.

In no event shall TONE Kaffeemaschinen AG be liable for any other damage or loss, including, but not limited to, lost profits, lost sales, loss of use of equipment, claims of Buyer's customers, cost of capital, cost of down time, cost of substitute equipment, facilities or services, or any other special, incidental or consequential damages.

10. WIRING DIAGRAM

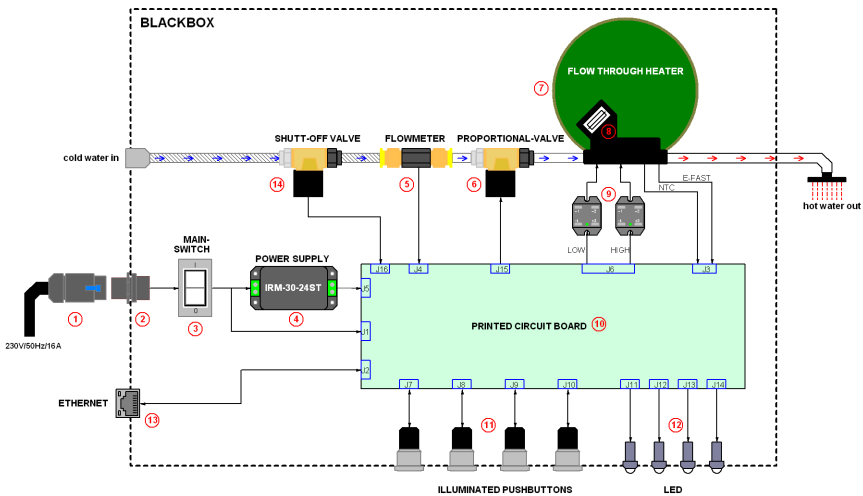

11. TONE WATER SPECIFICATION

Recommended water parameters for TONE TOUCH 03

VALUE	UNITS	MINIMUM	above this values a decarbonation is necessary	MAXIMUM
Conductivity/T.D.S	µS ppm	120 60	180 100	300 160
Total Hardness	ppm °dH	50 3	100 7	160 9
Total Iron	ppm			0,2 mg/l
Free Chlorine	ppm	free from chlorine and chlorine compounds		
Total Chlorine	ppm			
pH		6		8
Alkalinity	ppm	36		107
Carbonate Hardness	°dH	2	4	6
Chloride	ppm	0		30

Required water pressure : 1.5 - 3 bar (20 - 45 psi / 150-300kPa)

IRON: Iron is regulated via the drinking water ordinance with 0.2 mg/L

CHLORINE: Even small amounts of chlorine can lead to a change in taste

CARBONATE HARDNESS: Depending on the coffee; recommendation: individual tasting during set-up and subsequent fine-tuning of the filter blend, as the KH has the greatest influence.

BREW BASKET HOLDER

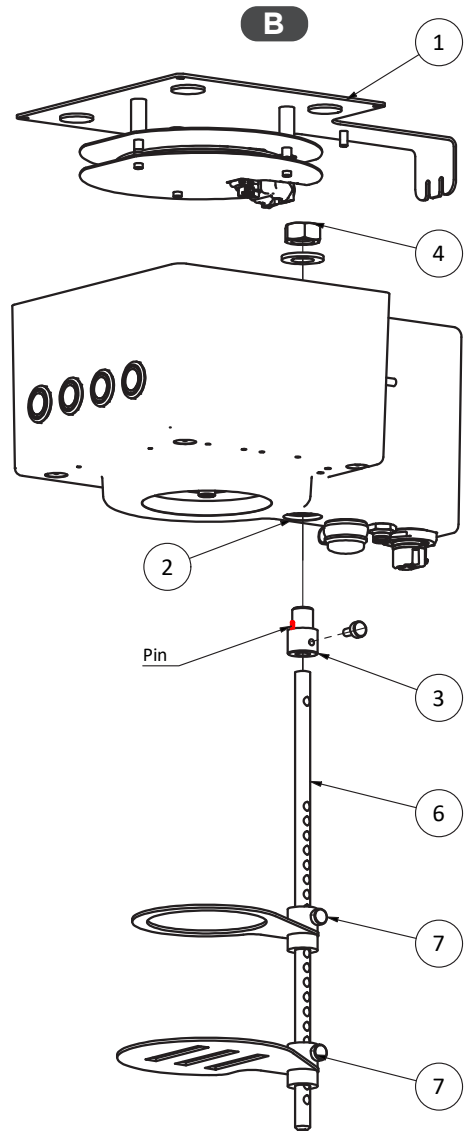
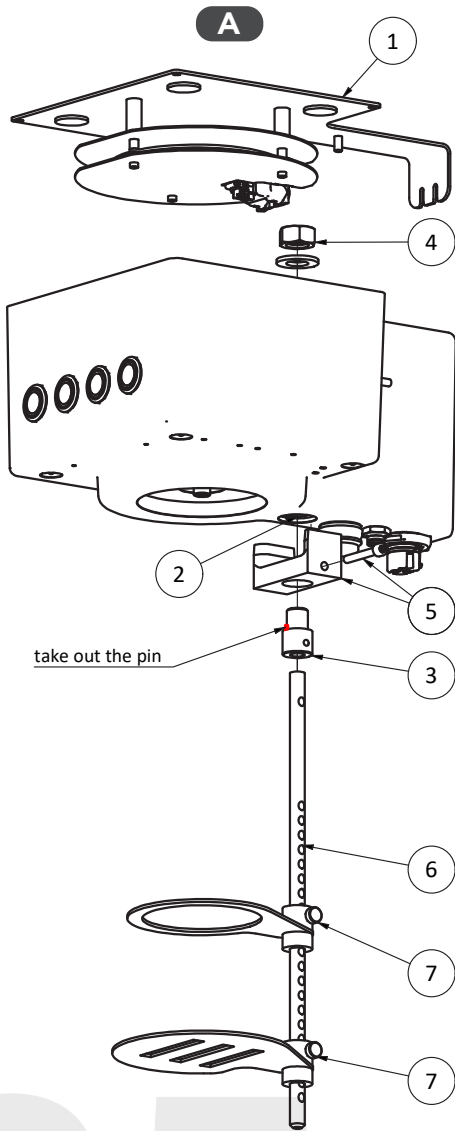

INSTRUCTIONS FOR MOUNTING THE BREW BASKET HOLDER

This manual is only required if you install the option “Brew Basket Holder” later to the purchase of the TOUCH 03

Version A “Blackbox without a groove”

- Remove the black lid from the black box (No.1)
- Remove the little black cap (No.2)
- Take away the little pin out of the screw (No.3) (pin is only needed for Version B)
- Fix the screw (No.3) with the washer and the 22mm nut (No.4)
- Before you tight it all the way orientate the screw with the alignment tool and the cylinder head screw (No.5)
- Tight the nut firmly (No.4, note that the screw does not rotate in the process)
- Loose the alignment tool and store it in a known place
- Insert the filter stand and fasten it with the knurled screw in the hole provided (No.6)
- Choose the desired height for both platforms (No.7)
- Brew some amazing coffee

Version B “Blackbox with a groove”

- Remove the black lid from the black box (No.1)
- Remove the little black cap (No.2)
- Fix the screw with the washer and the 22mm nut (No.4)
- Before you tight it all the way make sure the small pin (No.3) is located in the provided groove
- Tight the nut firmly (No.4, note that the screw does not rotate in the process)
- Insert the filter stand and fasten it with the knurled screw in the hole provided (No.6)
- Choose the desired height for both platforms (No.7)
- Brew some amazing coffee

**ATTENTION:**

Make sure that the cable connections will not be damaged during the assembling. Be careful during the entire process.

Declaration of Conformity

Manufacturer: **Thuner Kaffeemaschinenfabrik AG**
Address: Kasernenstrasse 5
3600 Thun
Switzerland

Device Name: **STONE TOUCH 03**

Model Type: 20.0422

Function: Coffee Machine

We herewith declare under our sole responsibility that the above mentioned device meets all the provisions of the following EC Council Directives and Standards. All supporting documentations are retained under the premises of the manufacturer.

DIRECTIVES

General Applicable Directive:
Machinery Directive 2006/42/EC

Applied Harmonized Standards, National Standards or other Normative Documents:

EN 60335-1:2012 + AA11:2014 + A13:2017 + A1:2019 + A14:2019 + A2:2019 + A15:2021, EN 60335-2-15:2016 + A11:2018, EN 60335-2-75:2004 + A1:2005 + A11:2006 + A2:2008 + A12:2010, EN 55014-1:2017, EN 55014-2:2015, EN IEC 61000-6-2:2019, EN 61000-6-3:2007

Date CE Mark was affixed: 31. August 2023

From Serial Number: 01115

Place, Date: CH-3600 Thun, 31. August, 2023

Signatures: 

Name:
Thomas Liebe

Function: CEO

TKM Thuner Kaffeemaschinenfabrik	Declaration of Conformity			
	Generated: 25.05.20 WM	Revision Status: Index a	Approved: 25.05.20 CW	Released: 25.05.20 WM

TONE

TONE Kaffeemaschinen AG
Kasernenstrasse 5
3600 Thun
Switzerland

contact@tone-swiss.com
www.tone-swiss.com

Download all TOUCH 03 brewer documents
here for a quick and easy start:



A printed version can be ordered at service@tone-swiss.com.