

DAIKIN

INSTALLATION MANUAL

AIR COOLED, DUCTED SPLIT TYPE AIR-CONDITIONERS (D & E SERIES)

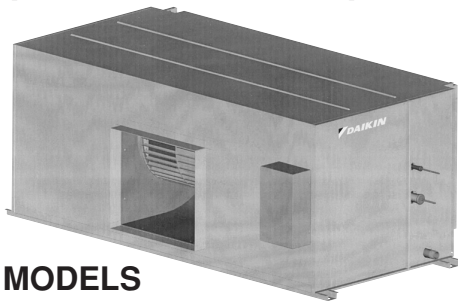

MODELS

R22 Cooling only

FDM75DXV1	RC75D(G)XY1
FDM100DXV1	RC100D(G)XY1
FD125DXY1	RC125D(G)XY1
FD150DXY1	RC150D(G)XY1
2FD150DXY1	RC75D(G)XY1 x 2
2FD200DXY1	RC100D(G)XY1 x 2
2FG250DXY1	RC125D(G)XY1 x 2
2FG300DXY1	RC150D(G)XY1 x 2
4FG400DXY1	RC100D(G)XY1 x 4
4FG500DXY1	RC125D(G)XY1 x 4

R22 Heatpump

FDYM75DXV1	RCY75E(G)XY1
FDYM100DXV1	RCY100E(G)XY1
FDY125EXY1	RCY125E(G)XY1
FDY150EXY1	RCY150E(G)XY1
2FDY150EXY1	RCY75E(G)XY1 x 2
2FDY200EXY1	RCY100E(G)XY1 x 2
2FGY250EXY1	RCY125E(G)XY1 x 2
2FGY300EXY1	RCY150E(G)XY1 x 2
3FGY300EXY1	RCY100E(G)XY1 x 3
3FGY350EXY1	RCY100E(G)XY1 RCY125E(G)XY1 x 2
4FGY400EXY1	RCY100E(G)XY1 x 4
3FGY450EXY1	RCY150E(G)XY1 x 3
4FGY500EXY1	RCY125E(G)XY1 x 4
4FGY600EXY1	RCY150E(G)XY1 x 4

R407C Cooling only

FDMP75DXV1	RCP75D(G)XY1
FDMP100DXV1	RCP100D(G)XY1
FDP125DXY1	RCP125D(G)XY1
FDP150DXY1	RCP150D(G)XY1
2FDP150DXY1	RCP75D(G)XY1 x 2
2FDP200DXY1	RCP100D(G)XY1 x 2
2FGP250DXY1	RCP125D(G)XY1 x 2
2FGP300DXY1	RCP150D(G)XY1 x 2
4FGP400DXY1	RCP100D(G)XY1 x 4
4FGP500DXY1	RCP125D(G)XY1 x 4

R407C Heatpump

FDYMP75DXV1	RCYP75E(G)XY1
FDYMP100DXV1	RCYP100E(G)XY1
FDYP125EXY1	RCYP125E(G)XY1
FDYP150EXY1	RCYP150E(G)XY1
2FDYP150EXY1	RCYP75E(G)XY1 x 2
2FDYP200EXY1	RCYP100E(G)XY1 x 2
2FGYP250EXY1	RCYP125E(G)XY1 x 2
2FGYP300EXY1	RCYP150E(G)XY1 x 2
3FGYP300EXY1	RCYP100E(G)XY1 x 3
3FGYP350EXY1	RCYP100E(G)XY1 RCYP125E(G)XY1 x 2
4FGYP400EXY1	RCYP100E(G)XY1 x 4
3FGYP450EXY1	RCYP150E(G)XY1 x 3
4FGYP500EXY1	RCYP125E(G)XY1 x 4
4FGYP600EXY1	RCYP150E(G)XY1 x 4

Installation Manual
Split Type Air Conditioner

English

Manuel D'installation
Climatiseurs Split System

Français

Installationshandbuch
Doppelfunktions-Klimagerät

Deutsch

Manuale Di Installazione
Condizionatore Split A

Italiano

Manual De Instalación
Equipo de air Acondicionado
de tipo Dividido de

Español

Руководство по установке
разделить Кондиционер
воздуха типа

Русский

Kurulum kılavuzu
Split Tipi Klima

Türkçe

IM-CC&SB-D/ER-0412(0)-Daikin
Part No.: R08019037636

OUTLINE AND DIMENSIONS

FD(Y)M(P) 75/100D

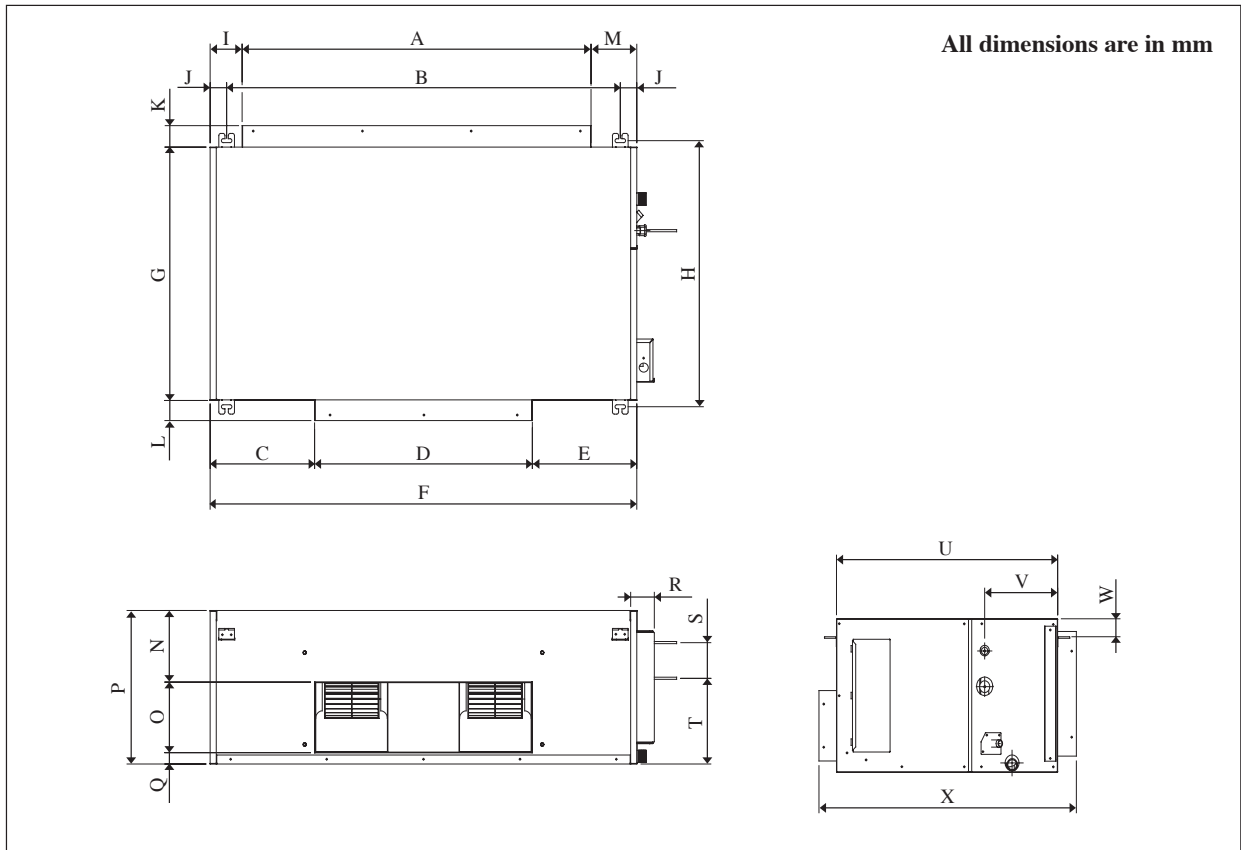

Dimension	A	B	C	D	E	F	G	H	I	J	K	L
75D	1120	1264	336	699	336	1370	710	746	103	53	63	56
100D	1349	1493	331	940	328	1599	710	746	103	53	60	56

Dimension	M	N	O	P	Q	R	S	T	U	V	W	X
75D	147	201	198	430	32	76	100	241	710	234	50	83
100D	147	201	198	430	32	76	100	237	710	234	50	83

FD(P) 125/150D
FDY(P) 125/150E

All dimensions are in mm

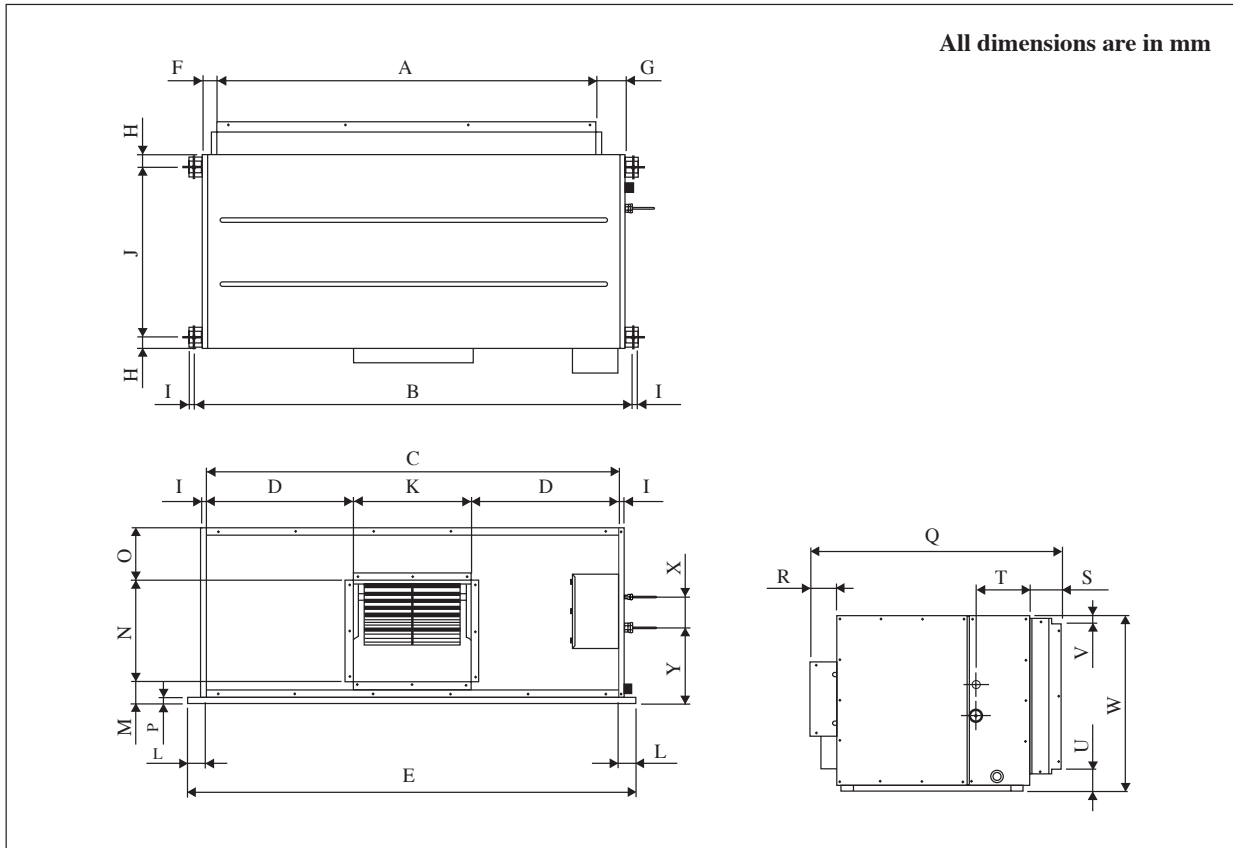

Dimension / Model	A	B	C	D	E	F	G	H	I	J	K	L	M
125D/125E	1526	1754	1654	590	1794	54	114	48	20	680	474	70	89
150D/150E	1805	2033	1933	730	2073	54	114	48	20	680	474	70	89

Dimension / Model	N	O	P	Q	R	S	T	U	V	W	X	Y
125D/125E	408	213	25	1009	104	130	215	89	35	710	125	305
150D/150E	408	213	25	1009	104	130	215	89	35	710	125	305

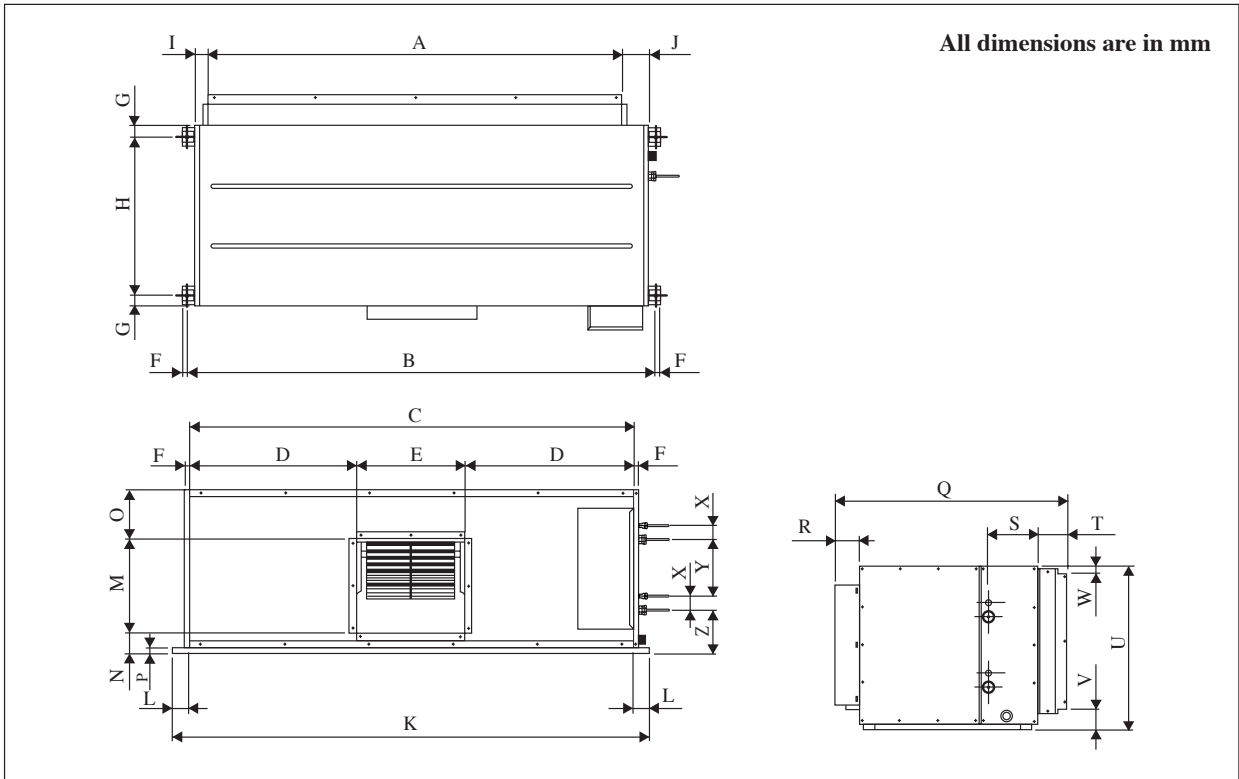

Dimension / Model	A	B	C	D	E	F	G	H	I	J	K	L	M
150D/150E	1805	2033	1933	730	474	20	48	680	54	114	2073	70	408

Dimension / Model	N	O	P	Q	R	S	T	U	V	W	X	Y	Z
150D/150E	89	213	25	1014	109	215	130	710	89	35	60	245	187

2FG(P) 200/250/300D

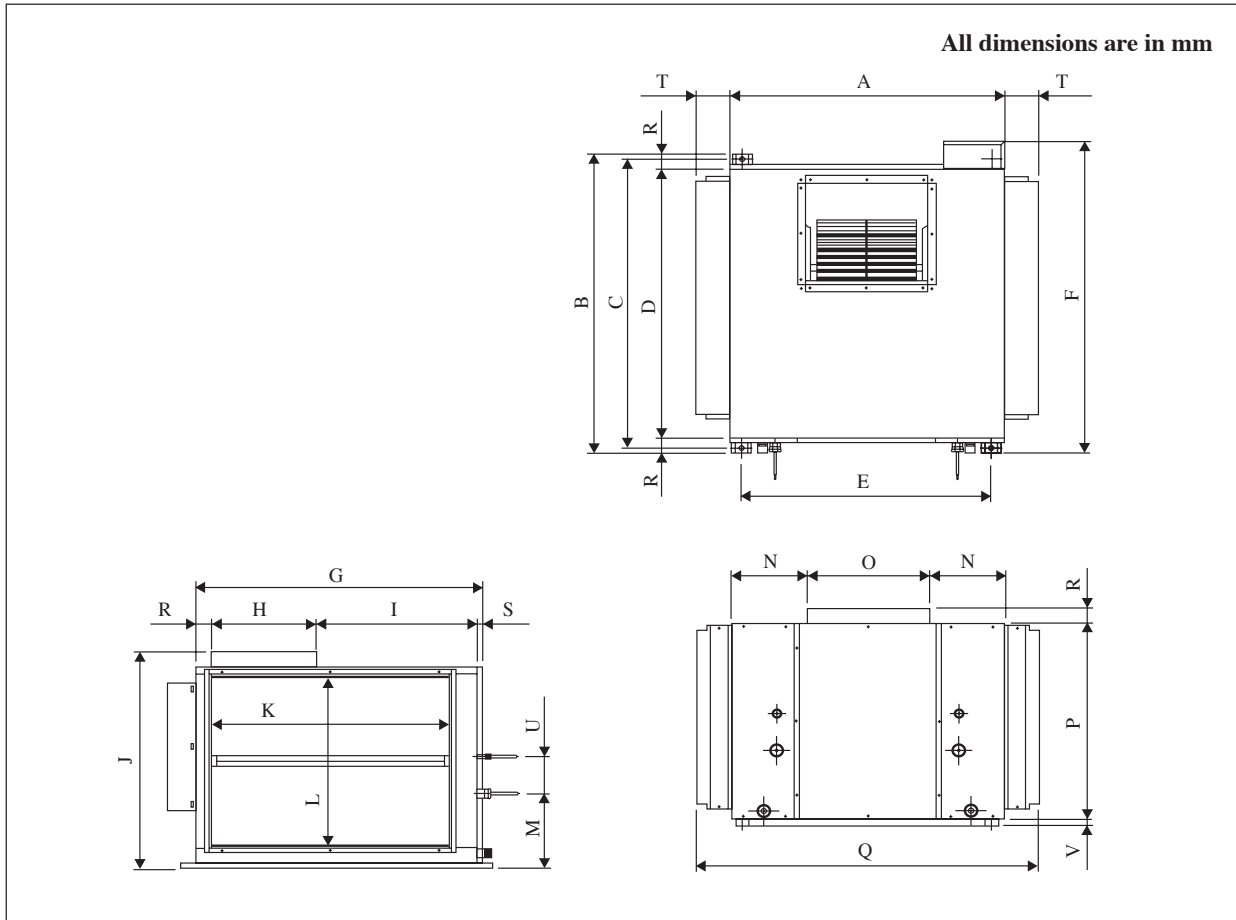

Model \ Dimension	A	B	C	D	E	F	G	H	I	J	K
200D	1064	1209	1169	1089	967	1260	1113	408	623	881	922
250D	1226	1298	1258	1178	1129	1349	1202	482	638	982	1011
300D	1226	1501	1461	1381	1129	1552	1405	482	841	982	1214

Model \ Dimension	L	M	N	O	P	Q	R	S	T	U	V
200D	678	301	295	474	796	1324	60	22	130	150	25
250D	779	353	333	560	897	1486	60	22	130	150	25
300D	779	353	353	560	897	1486	60	22	130	150	25

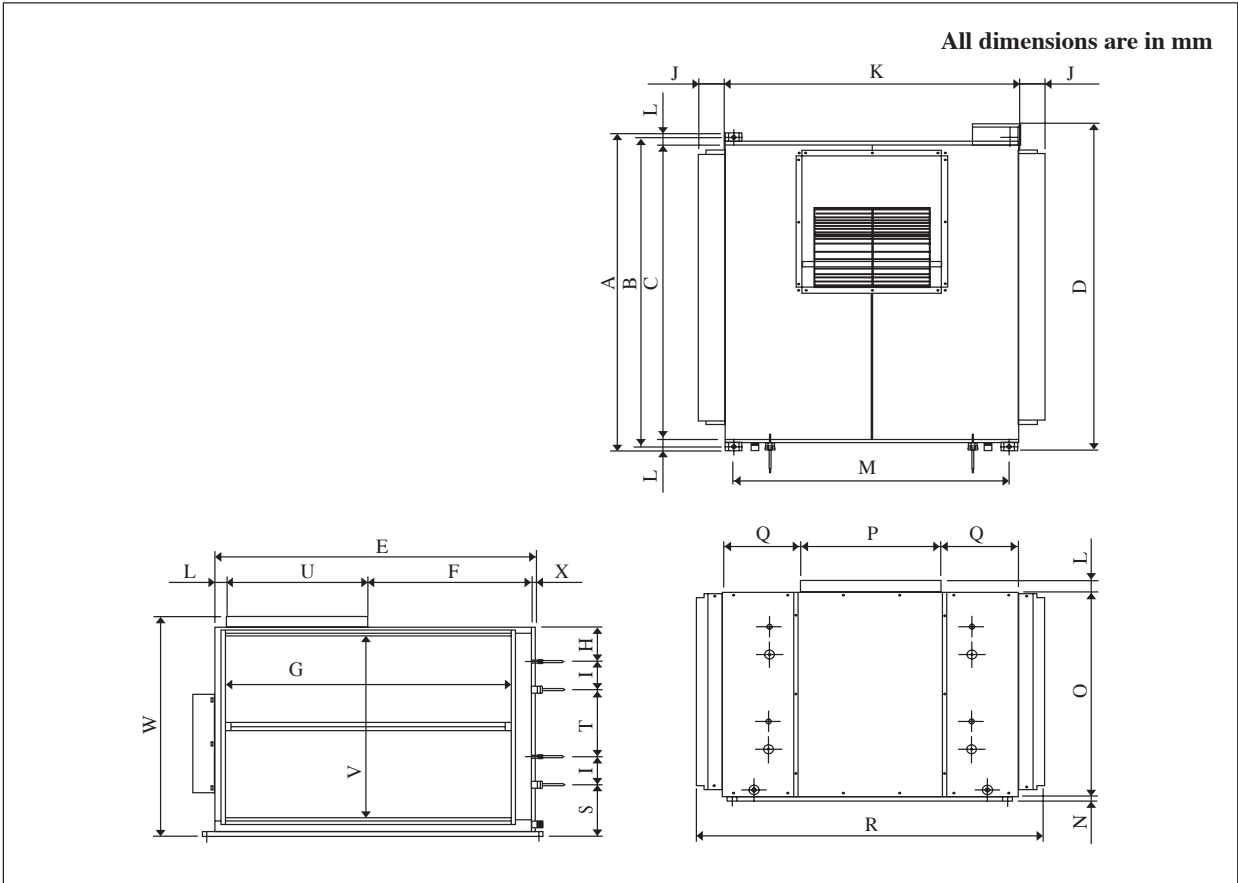

Dimension \ Model	A	B	C	D	E	F	G	H	I	J	K	L
400D	1691	1651	1571	1742	1596	816	1405	185	150	130	1462	60
500D	2047	2007	1927	2098	1952	1172	1760	185	150	130	1462	60

Dimension \ Model	M	N	O	P	Q	R	S	T	U	V	W	X
400D	1367	25	1090	695	384	1722	273	358	698	972	1175	22
500D	1367	25	1090	695	384	1722	273	358	698	972	1175	22

2FGY(P) 200E

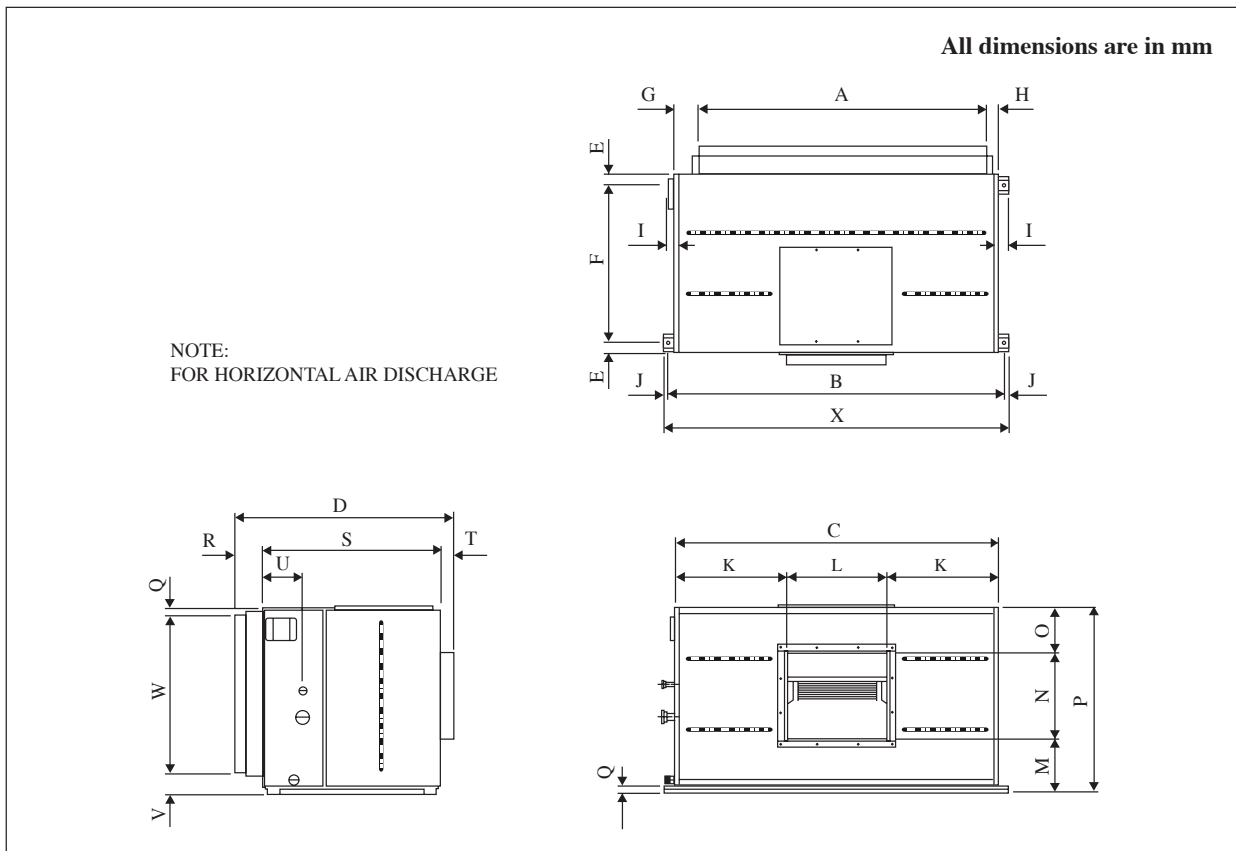

Dimension Model	A	B	C	D	E	F	G	H	I	J	K	L
200E	1624	1834	1794	1040	48	754	117	53	50	20	660	474

Dimension Model	M	N	O	P	Q	R	S	T	U	V	W	X
200E	257	408	220	885	35	130	850	60	193	103	747	1894

2FGY(P) 250/300E
 3FGY(P) 300/350/450E
 4FGY(P) 400/500E

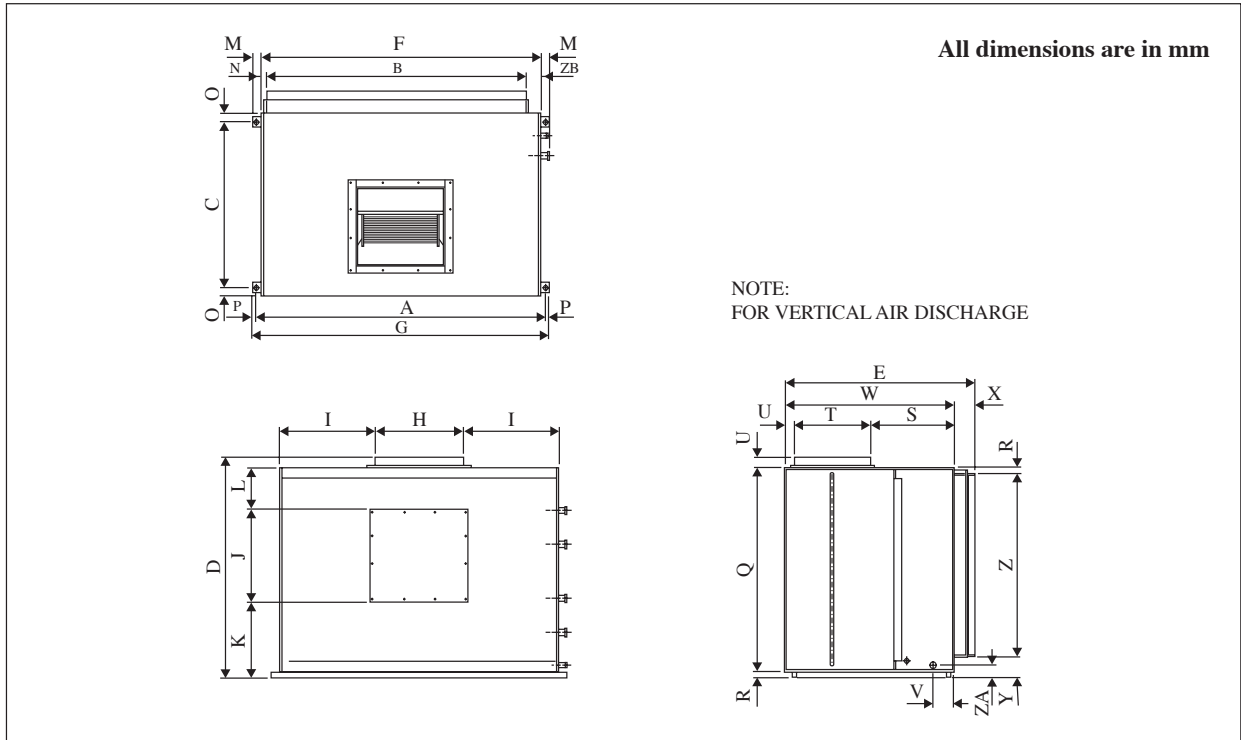

Dimension	A	B	C	D	E	F	G	H	I	J	K	L	M	N	O
250/300E	1826	1636	973	1231	1259	1766	1866	560	603	542	444	245	50	35	48
350E	2082	1852	973	1451	1259	2022	2122	560	731	542	407	286	50	55	48
400/450/500E	2234	2004	1271	1451	1556	2174	2274	694	740	758	407	286	50	55	48

Dimension	P	Q	R	S	T	U	V	W	X	Y	Z	ZA	ZB
250/300E	20	1196	35	528	482	60	129	1069	130	123	1073	73	95
350E	20	1451	35	528	482	60	129	1069	130	123	1326	73	115
400/450/500E	20	1451	35	578	698	60	129	1366	130	123	1326	73	115

4FGY(P) 600E

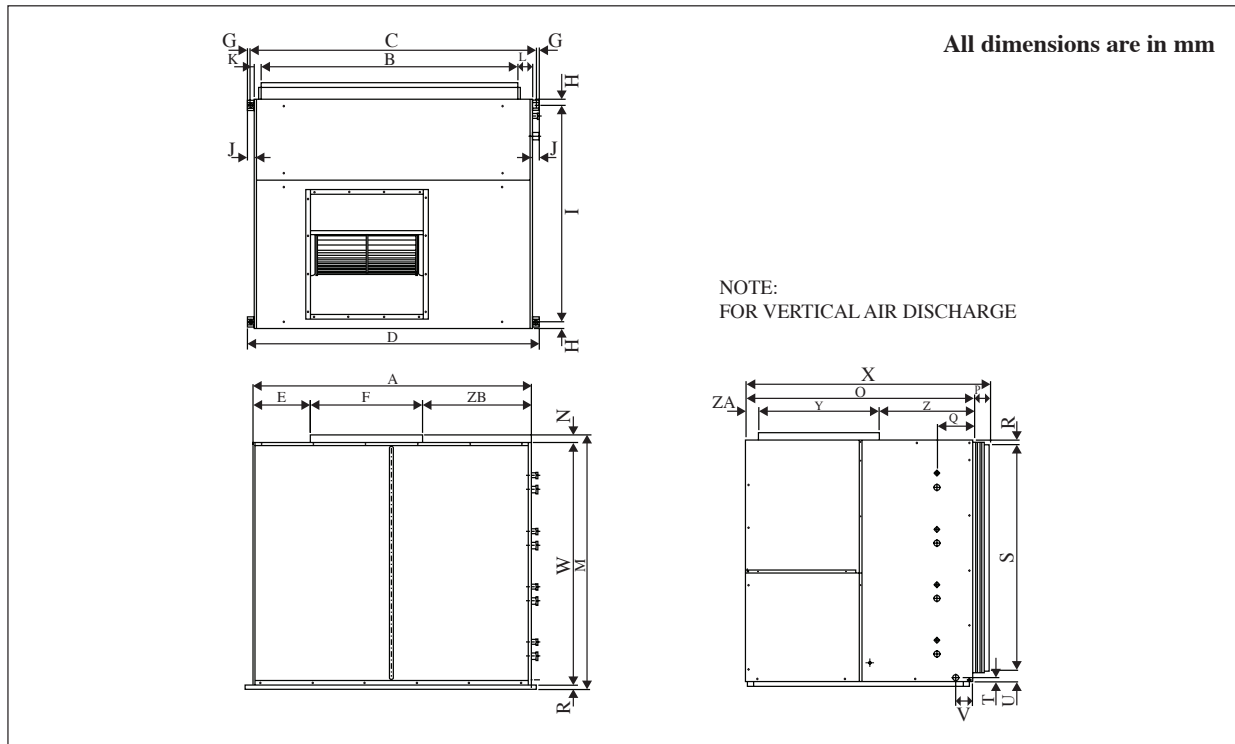

Dimension	A	B	C	D	E	F	G	H	I	J	K	L	M	N
Model														
600E	2174	2004	2234	2274	450	874	20	48	1679	50	55	115	1978	60

Dimension	O	P	Q	R	S	T	U	V	W	X	Y	Z	ZA	ZB
Model														
600E	1775	130	286	35	1758	38	90	129	1883	1905	939	736	100	850

RC(P) 75/100/125/150D
RCY(P) 75/100/125/150E

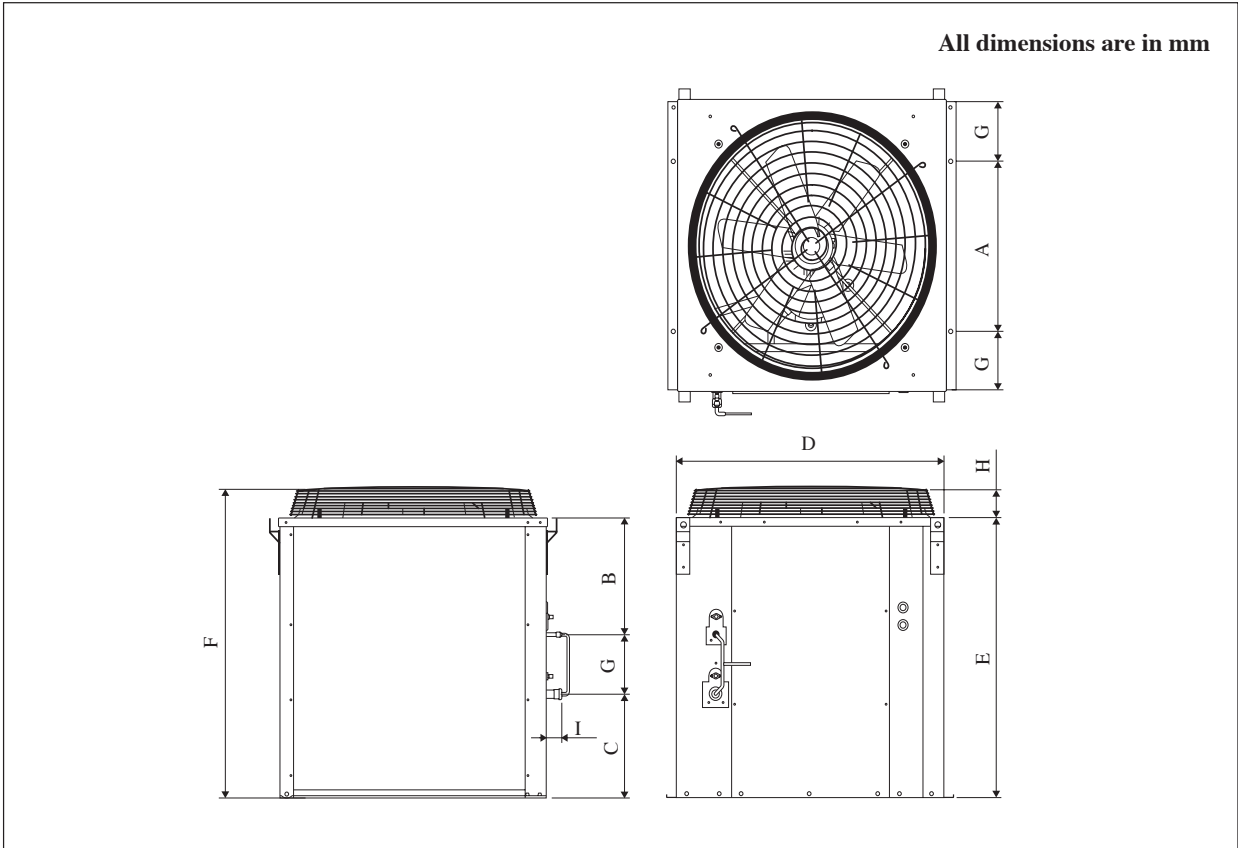

Model \ Dimension	A	B	C	D	E	F	G	H	I
75/100D 75/100E	571	396	350	981	946	1041	200	95	50
125D 150E	673	396	350	1083	946	1041	200	95	50
150D 150E	673	493	354	1083	1047	1142	200	95	50

INSTALLATION MANUAL

This manual provides the procedures of installation to ensure a safe and good standard of operation for the air conditioner unit. Special adjustment may be necessary to suit local requirements.

Before using your air conditioner, please read this instruction manual carefully and keep it for future reference.

This appliance is intended to be used by expert or trained users in shops, in light industry and on farms, or for commercial use by lay persons.

This appliance is not intended for use by persons, including children, with reduced physical, sensory or mental capabilities, or lack of experience and knowledge, unless they have been given supervision or instruction concerning use of the appliance by a person responsible for their safety.

Children should be supervised to ensure that they do not play with the appliance.

SAFETY PRECAUTIONS

⚠ WARNING

- Installation and maintenance should be performed by qualified persons who are familiar with local code and regulation, and experienced with this type of appliance.
- All field wiring must be installed in accordance with the national wiring regulation.
- Ensure that the rated voltage of the unit corresponds to that of the name plate before commencing wiring work according to the wiring diagram.
- The unit must be GROUND^{ED} to prevent possible hazard due to insulation failure.
- All electrical wiring must not touch the refrigerant piping, or any moving parts of the fan motors.
- Confirm that the unit has been switched OFF before installing or servicing the unit.
- Disconnect from the main power supply before servicing the air conditioner unit.
- DO NOT pull out the power cord when the power is ON. This may cause serious electrical shocks which may result in fire hazards.
- Keep the indoor and outdoor units, power cable and transmission wiring, at least 1m from TVs and radios, to prevent distorted pictures and static. {Depending on the type and source of the electrical waves, static may be heard even when more than 1m away}.

Important information regarding the refrigerant used

This product contains fluorinated greenhouse gases covered by the Kyoto Protocol.

Do not vent gases into the atmosphere.

Refrigerant type: R407C

GWP⁽¹⁾ value: 1652.5

⁽¹⁾ GWP = global warming potential

Please fill in with indelible ink,

- ① the factory refrigerant charge of the product,
- ② the additional refrigerant amount charged in the field and
- ① + ② the total refrigerant charge

on the refrigerant charge label supplied with the product.

The filled out label must be adhered in the proximity of the product charging port (e.g. onto the inside of the service cover).

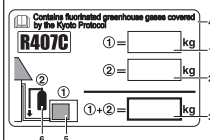

- 1 factory refrigerant charge of the product: see unit name plate⁽²⁾
- 2 additional refrigerant amount charged in the field
- 3 total refrigerant charge
- 4 Contains fluorinated greenhouse gases covered by the Kyoto Protocol
- 5 outdoor unit
- 6 refrigerant cylinder and manifold for charging

⁽²⁾ In case of multiple indoor systems, only 1 label must be adhered*, mentioning the total factory refrigerant charge of all indoor units connected in the refrigerant system.

Periodical inspections for refrigerant leaks may be required depending on European or local legislation. Please contact your local dealer for more information.

* on the outdoor unit

⚠ CAUTION

Please take note of the following important points when installing.

- Do not install the unit where leakage of flammable gas may occur.

⊘ If gas leaks and accumulates around the unit, it may cause fire ignition.

- Ensure that the drainage piping is connected properly.

ⓘ If the drainage piping is not connected properly, it may cause water leakage which will dampen the furniture.

- Do not overcharge the unit.

⊘ This unit is factory pre-charged. Overcharge will cause over-current or damage to the compressor.

- Ensure that the unit's panel is closed after service or installation.

ⓘ Unsecured panels will cause the unit to operate noisily.

- Sharp edges and coil surfaces are potential locations which may cause injury hazards. Avoid from being in contact with these places.

- Before turning off the power supply, set the remote controller's ON/OFF switch to the "OFF" position to prevent the nuisance tripping of the unit. If this is not done, the unit's fans will start turning automatically when power resumes, posing a hazard to service personnel or the user.

- Do not install the units at or near doorway.

- Do not operate any heating apparatus too close to the air conditioner unit or use in room where mineral oil, oil vapour or oil steam exist, this may cause plastic part to melt or deform as a result of excessive heat or chemical reaction.

- When the unit is used in kitchen, keep flour away from going into suction of the unit.

- This unit is not suitable for factory used where cutting oil mist or iron powder exist or voltage fluctuates greatly.

- Do not install the units at area like hot spring or oil refinery plant where sulphide gas exists.

- Ensure the color of wires of the outdoor unit and the terminal markings are same to the indoors respectively.

- **IMPORTANT : DO NOT INSTALL OR USE THE AIR CONDITIONER UNIT IN A LAUNDRY ROOM.**

- Don't use joined and twisted wires for incoming power supply.

- The equipment is not intended for use in a potentially explosive atmosphere.

INSTALLATION OF THE INDOOR UNIT

Mounting

Ensure that the overhead supports are strong enough to hold the unit's weight. Position hanger rods and check for alignment with the unit. Check that hangers are secure and that the base of fan-coil unit is level in the two horizontal directions, taking into account the gradient recommended for drainage flow as shown.

Check the gradient recommended for drainage flow as follow.

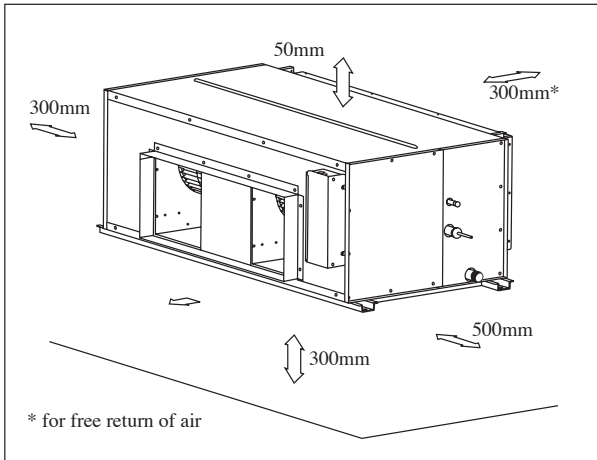
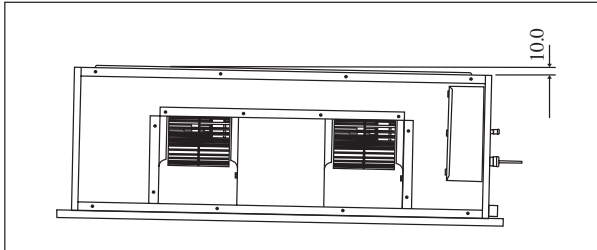

Provide clearance for servicing and optimal air flow as shown in the diagram.

The indoor unit must be installed such that there is no short circuit of cool discharge with air discharge.

Respect the installation clearance.

FG(Y)M(P) 75~100D

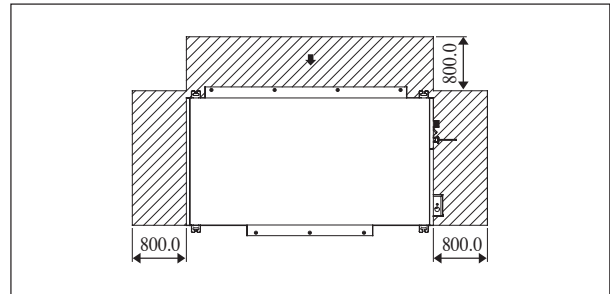

FD(P) 125 ~ 150D / FDY(P) 125~200E

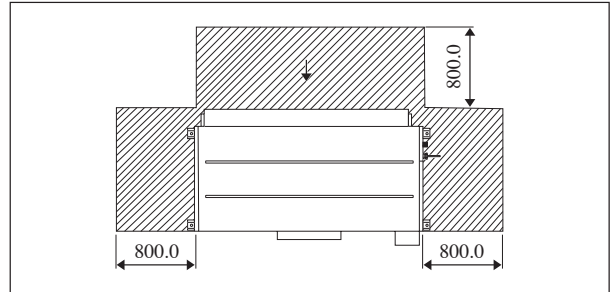

FG(P) 200 ~ 500D

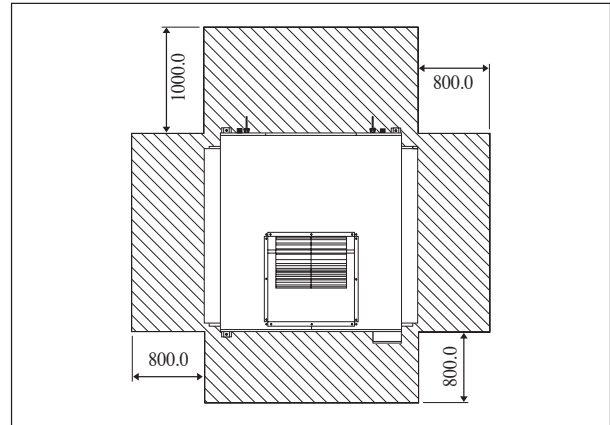

FGY(P) 250~600E

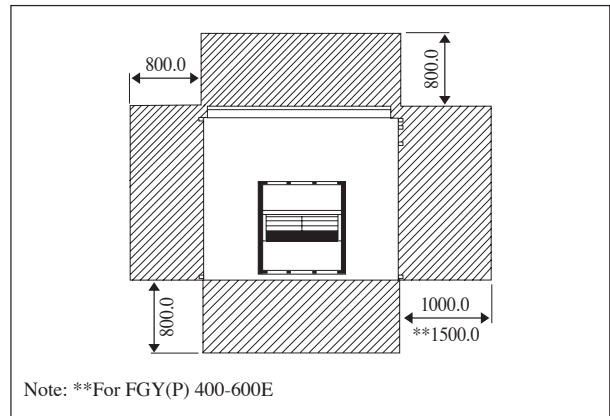

All dimensions in mm

INSTALLATION OF THE OUTDOOR UNIT

Location For Installation

Install the outdoor unit in such way that air distributed by the outdoor unit cannot be drawn in again (as in the case of short circuit of discharge air). Allow sufficient space for maintenance around the unit.

Ensure that there are no obstruction of air flow into or out of the unit. Remove obstacles which block air intake or discharge.

- The location must be well ventilated, so that the unit can draw and distribute plenty of air.
- A place capable of bearing the weight of the outdoor unit and isolating noise and vibration.
- A place protected from direct sunlight. Otherwise use an awning for protection, if necessary.
- A place where smooth drainage of rain water and water formed by defrosting is acceptable.
- A place where the unit will not be buried in snow.
- A place where air outlet port is not exposed to strong wind.
- A place where the air discharge and operating sound level will not annoy the neighbours.
- The location must not be susceptible to dust or oil mist.

When two or more outdoor units are installed in a location, they must be positioned such that one unit will not be taking the discharge air from another.

This also applies when two or more units are installed one above the other. The units must all face the same direction, or opposite direction (back to back), such that air short circuit does not occur.

⚠ CAUTION

If the condensing unit is operated in an atmosphere containing oils (including machine oils), salt (coastal area), sulfide gas (near hot spring, oil refinery plant), such substances may lead to failure of the unit.

Installation Clearance

Outdoor unit must be installed such that there is no short circuit of the discharge air or obstruction to smooth air flow.

RC(P) 75/100/125/150D

RCY(P) 75/100/125/150E

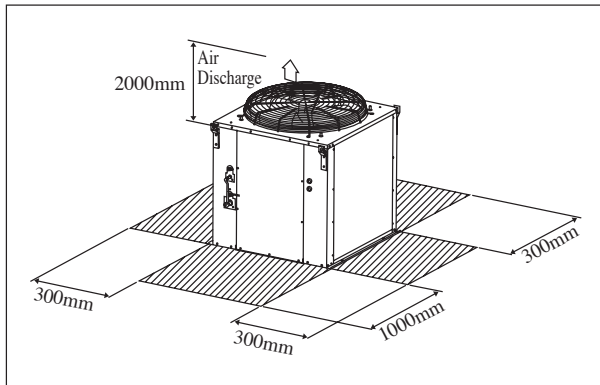

REFRIGERANT PIPING

Allowable Pipe Length and Elevation

If the pipe is too long, both the capacity and reliability of the unit will drop. As the number of bends increases, resistance to the flow of refrigerant system increases, thus lowering cooling capacity. As a result, the compressor may become defective. Always choose the shortest path and follow the recommendations as tabulated below:

Model	RC(P)75D RCY(P)75E	RC(P)100D RCY(P)100E	RC(P)125D RCY(P)125E	RC(P)150D RCY(P)150E
Max Allowable Length, m	35	35	35	35
Max Allowable Elevation, m	20	20	20	20
Max Allowable Bend	8	8	8	8
Liquid pipe size, mm(in)	12.7(1/2")	15.9(5/8")	15.9(5/8")	15.9(5/8")
Gas pipe size, mm(in)	25.4(1")	28.6(1 1/8")	34.9(1 3/8")	34.9(1 3/8")

Bending must be carefully made so as not to crush the pipe. Use a pipe bender to bend a pipe where possible.

⚠ CAUTION

Our guarantee on the performance of our air-conditioners is strictly revoked if the height, length and/or no. of bends of the refrigerant piping system installed is beyond the limit above.

Piping Works And Flaring Technique

- Do not use contaminated or damaged copper tubing. If any piping, evaporator or condenser had been exposed or had been opened for 15 seconds or more, the system must be vacuumed. Generally, do not remove plastic, rubber plugs and brass nuts from the valves, fittings, tubings and coils until it is ready for connection.
- If any brazing work is required, ensure that the nitrogen gas is passed through piping and joints while the brazing work is being done. This will eliminate soot formation on the inside walls of the copper tubings.
- Cut the pipe stage by stage, advancing the blade of pipe cutter slowly. Extra force and deep cut will cause more distortion of pipe and therefore extra burr. See Figure I.
- Remove burrs from cut edges of pipes with a remover as shown in Figure II. This will avoid unevenness on the flare faces which will cause gas leak. Hold the pipe on top position and burr remover at lower position to prevent metal chips from entering the pipe.
- Insert the flare nuts mounted on the connection parts of both indoor and outdoor unit, into the copper pipes.
- The exact length of pipe protruding from the face of the swaging block is determined by the flaring tool. See Figure III.
- Fix the pipe firmly on the swaging block. Match the centers of both the flare die and the flaring punch, and tighten flaring punch fully.

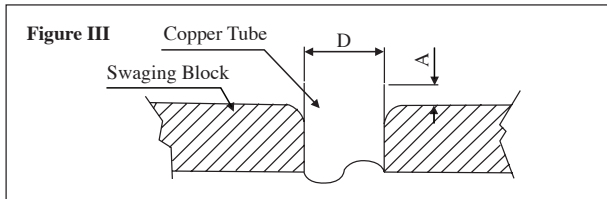
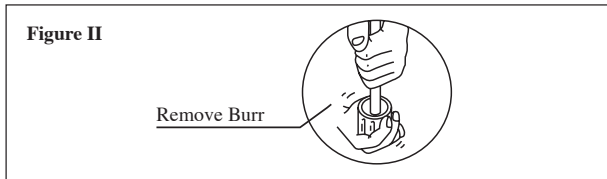
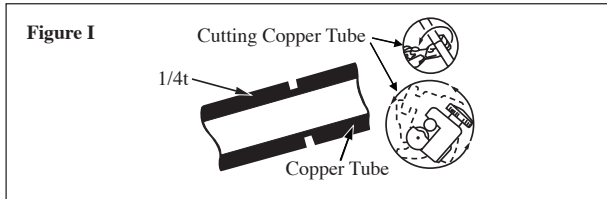

Special Precautions When Mounting TXV Bulb

- TXV bulb should be clamped to the suction line near the evaporator outlet, and if possible, on a horizontal run.
- Clean suction line completely before clamping the bulb in place.
- Clamp the bulb to a free draining suction line.
- Insulate the bulb from ambient.

Note: The TXV bulb must be fixed at suction line at 8 o'clock or 4 o'clock.

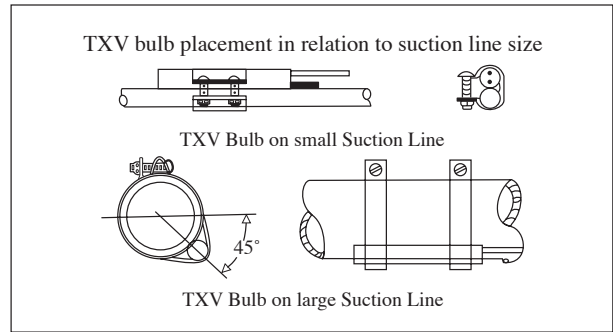

Piping Connection To The Units

- Align the center of the piping and sufficiently tighten the flare nut with fingers. See Figure IV.
- Finally, tighten the flare nut with torque wrench until the wrench clicks.
- When tightening the flare nut with the torque wrench, ensure that the direction for tightening follows the arrow on the wrench.
- The refrigerant pipe connection are insulated by closed cell polyurethane.

Ø Tube, D		A (mm)	
Inch	mm	Imperial (Wing-nut Type)	Rigid (Clutch Type)
1/4"	6.35	1.3	0.7
3/8"	9.52	1.6	1.0
1/2"	12.70	1.9	1.3
5/8"	15.88	2.2	1.7
3/4"	19.05	2.5	2.0

Pipe Size, mm (in)	Torque, Nm / (ft-lb)
6.35 (1/4")	18 (13.3)
9.52 (3/8")	42 (31.0)
12.70 (1/2")	55 (40.6)
15.88 (5/8")	65 (48.0)
19.05 (3/4")	78 (57.6)

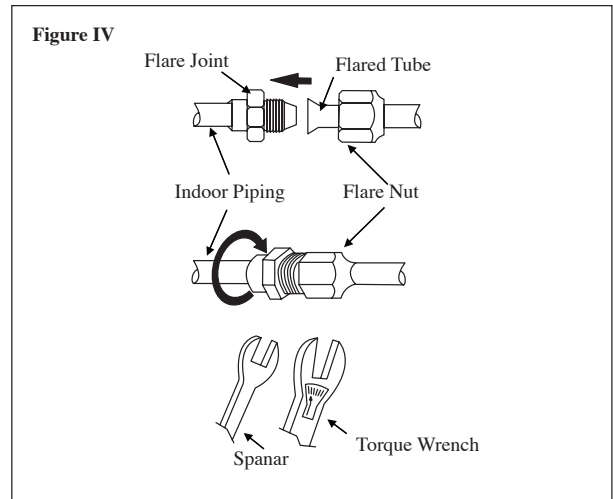

ELECTRICAL CONNECTION

IMPORTANT: * These values are for information only, they should be checked and selected to comply with the local and/or national codes and regulations. They are also subjected to the type of installation and size of conductors.
 ** The appropriate voltage range should be checked with data label on the unit.

Cooling Unit

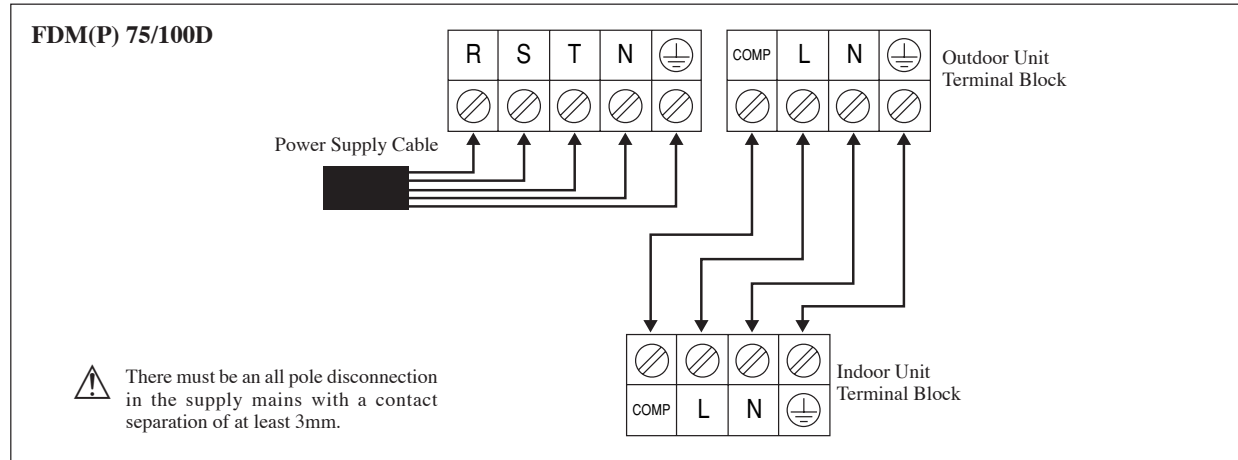

Model	Indoor Outdoor	FDM(P) 75D	FDM(P) 100D
		RC(P) 75D	RC(P) 100D
Voltage range**	Indoor	220-240V/1PH/50Hz+⊕	
	Outdoor	380-415V/3PH/50Hz+⊕	
Power supply cable size* /mm ²			
A) Indoor		1	1
B) Outdoor		2.5	4
C) Total		2.5	4
Number of conductors			
A) Indoor		-	-
B) Outdoor		5	5
Interconnection cable size* / mm ²		1	1
Number of conductors		4	4
Recommended time delay fuse* /A			
A) Indoor		10	12
B) Outdoor		25	32
C) Total		32	40

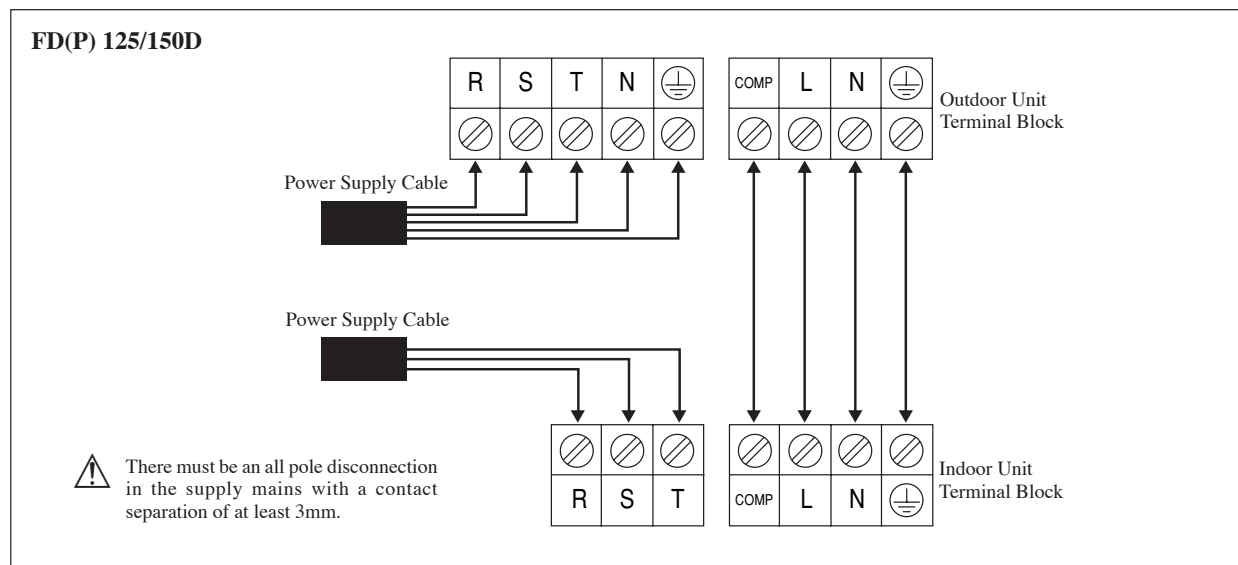

Model	Indoor	FD(P) 125D	FD(P) 150D
	Outdoor	RC(P) 125D	RC(P) 150D
Voltage range**	Indoor Outdoor	380-415V/3PH/50Hz+⊕	
Power supply cable size* /mm ²			
A) Indoor		1	1
B) Outdoor		4	6
C) Total		4	6
Number of conductors			
A) Indoor		3	3
B) Outdoor		5	5
Interconnection cable size* / mm ²		1	1
Number of conductors		4	4
Recommended time delay fuse* /A			
A) Indoor		6	6
B) Outdoor		40	50
C) Total		40	50

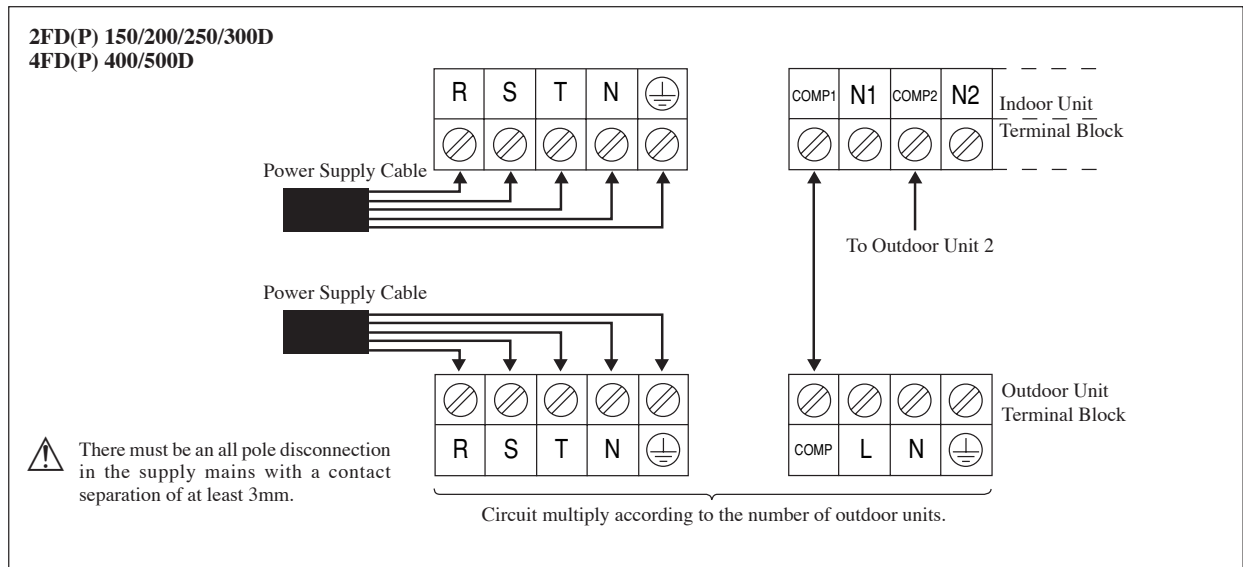

Model	Indoor	2FD(P) 150D	2FD(P) 200D	2FG(P) 250D	2FG(P) 300D	4FG(P) 400D	4FG(P) 500D
	Outdoor	RC(P) x 2	RC(P) 100D x 2	RC(P) 125D x 2	RC(P) 150D x 2	RC(P) 100D x 4	RC(P) 125D x 4
Voltage range**	Indoor Outdoor	380-415V/3PH/50Hz+⊕					
Power supply cable size* /mm ²							
A) Indoor		1	1	1	1	1.5	4
B) Outdoor		2.5	2.5	4	6	2.5	4
C) Total		10	10	16	25	35	50
Number of conductors							
A) Indoor		5	5	5	5	5	5
B) Outdoor		5	5	5	5	5	5
Interconnection cable size* / mm ²		1	1	1	1	1	1
Number of conductors		1 x 2	1 x 2	1 x 2	1 x 2	1 x 4	1 x 4
Recommended time delay fuse* /A							
A) Indoor		6	12	16	20	20	40
B) Outdoor		25	32	40	50	32	40
C) Total		50	63	80	100	150	175

Heat Pump

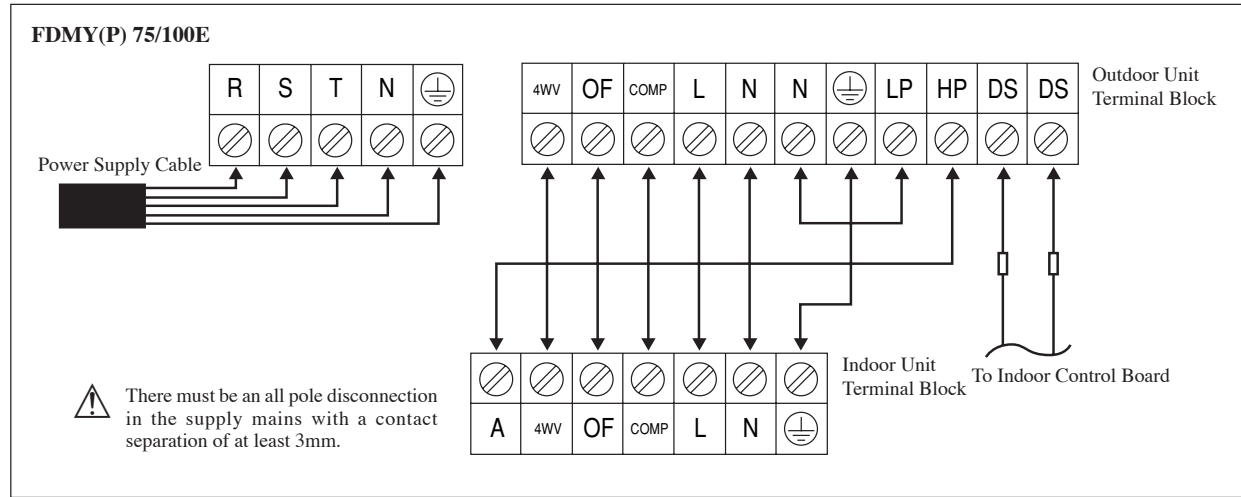

Model	Indoor	FDMY(P) 75D	FDMY(P) 100D
	Outdoor	RCY(P) 75E	RCY(P) 100E
Voltage range**	Indoor	220-240V/1PH/50Hz+⊕	
	Outdoor	380-415V/3PH/50Hz+⊕	
Power supply cable size* /mm ²	A) Indoor	1	1
	B) Outdoor	2.5	4
Number of conductors	A) Indoor	2.5	4
	B) Outdoor	-	-
Interconnection cable size* / mm ²	A) Indoor	1	1
	B) Outdoor	5	5
Recommended time delay fuse* /A	A) Indoor	7	7
	B) Outdoor	10	12
Number of conductors	A) Indoor	25	40
	B) Outdoor	32	40

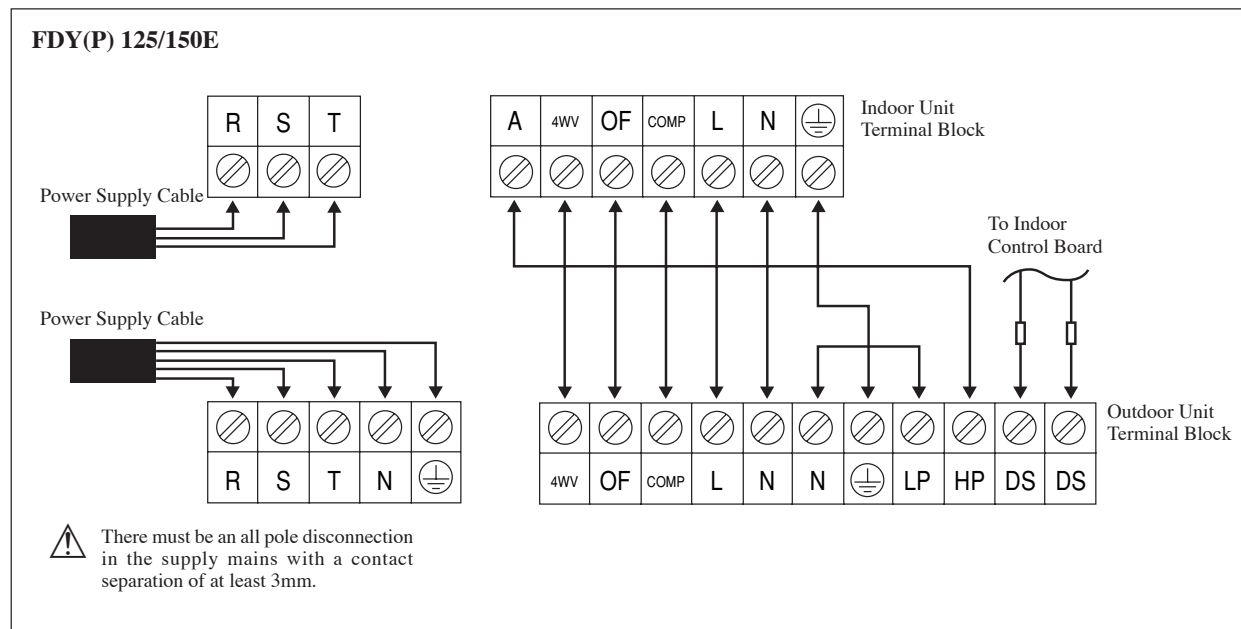

Model	Indoor	FDY(P) 125E	FDY(P) 150E
	Outdoor	RCY(P) 125E	RCY(P) 150E
Voltage range**	Indoor	380-415V/3PH/50Hz+⊕	
	Outdoor		
Power supply cable size* /mm²			
A) Indoor		1	1
B) Outdoor		4	6
C) Total		4	6
Number of conductors			
A) Indoor		3	3
B) Outdoor		5	5
Interconnection cable size* / mm²		1	1
Number of conductors		7	7
Recommended time delay fuse* /A			
A) Indoor		6	6
B) Outdoor		32	50
C) Total		40	50

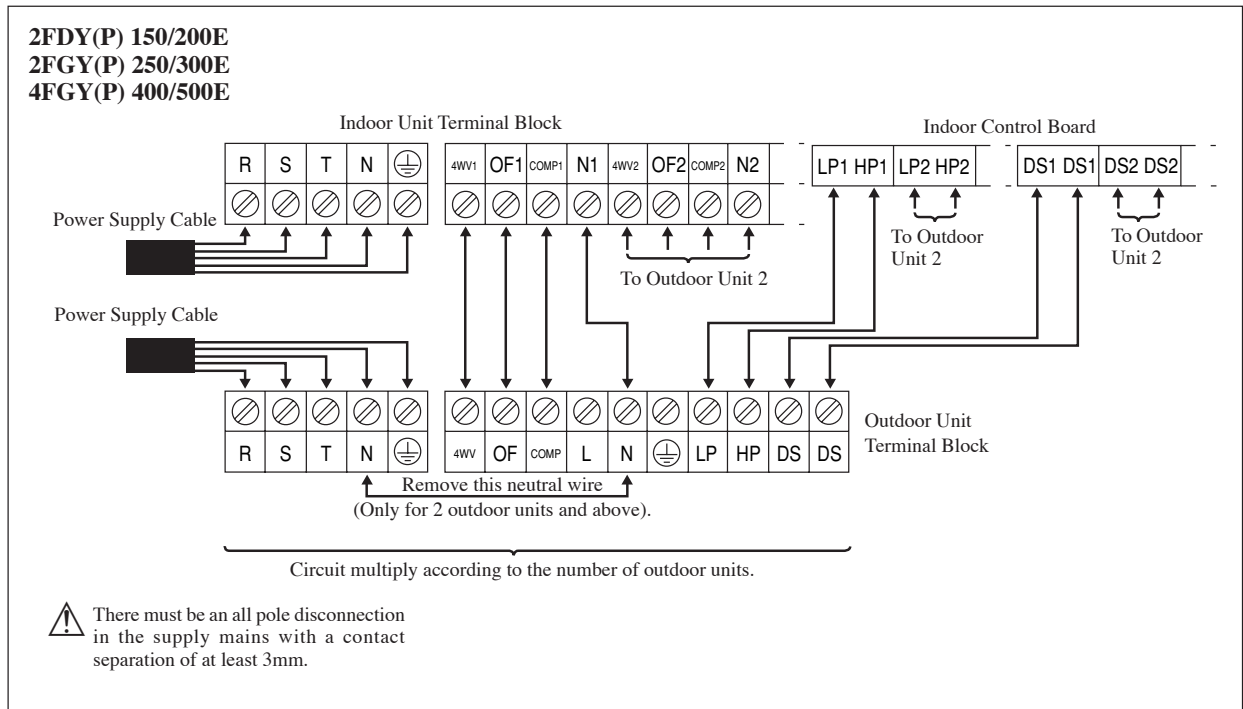

Model	Indoor	2FDY(P) 150E	2FDY(P) 200E	2FGY(P) 250E	2FGY(P) 300E	3FGY(P) 350E	4FGY(P) 400E	4FGY(P) 500E
	Outdoor	RCY(P) 75E x 2	RCY(P) 100E x 2	RCY(P)125E x 2	RCY(P) 150E x 2	RCY(P) 100E RCY(P) 125E x 2	RCY(P) 100E x 4	RCY(P) 125E x 4
Voltage range**	Indoor	380-415V/3PH/50Hz+⊕						
	Outdoor							
Power supply cable size* / mm²								
A) Indoor		1	1	1	1	1.5	1.5	2.5
B) Outdoor		2.5	4	4	6	4	4	4
C) Total		10	10	16	25	25	35	35
Number of conductors								
A) Indoor		5	5	5	5	5	5	5
B) Outdoor		5	5	5	5	5	5	5
Interconnection cable size*/mm²		1	1	1	1	1	1	1
Number of conductors		6 x 2	6 x 2	6 x 2	6 x 2	6 x 3	6 x 4	6 x 4
Recommended time delay fuse*/A								
A) Indoor		6	10	16	16	20	20	32
B) Outdoor		25	32	32	50	32	32	32
C) Total		50	63	80	100	100	150	150

- All wires must be firmly connected.
- Make sure all the wire do not touch the refrigerant pipings, compressor or any moving parts.
- The connecting wire between the indoor unit and the outdoor unit must be clamped by using provided cord anchorage.
- The power supply cord must be equivalent to H07RN-F which is the minimum requirement.
- Make sure no external pressure is applied to the terminal connectors and wires.
- Make sure all the covers are properly fixed to avoid any gap.
- Use round crimp-style terminal for connecting wires to the power supply terminal block. Connect the wires by matching to the indication on terminal block. (Refer to the wiring diagram attached on the unit).

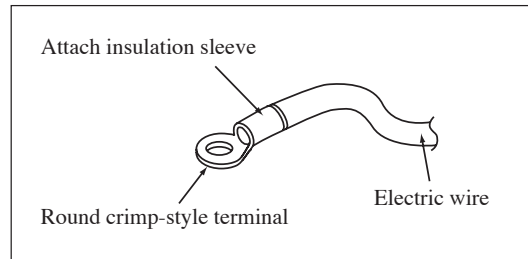

- Used the correct screwdriver for terminal screws tightening. Unsuitable screwdrivers can damage the screw head.
- Over tightening can damage the terminal screws.
- Do not connect wire of different gauge to same terminal.
- Keep wiring in an orderly manner. Prevent the wiring from obstructing other parts and the terminal box cover.

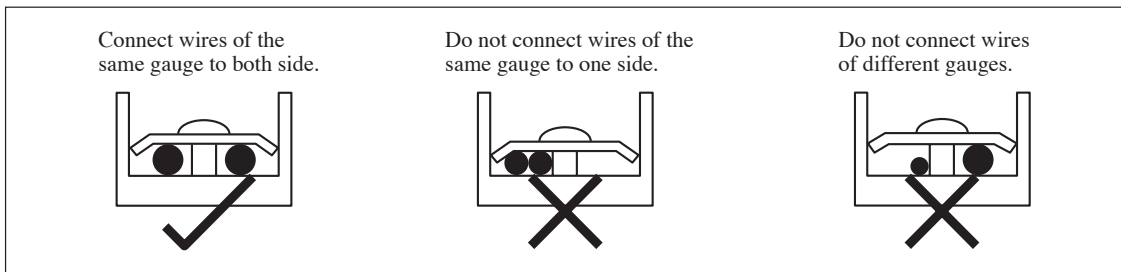

SPECIAL PRECAUTIONS WHEN DEALING WITH R407C UNIT

- R407C is a zeotropic refrigerant mixture which has zero ozone depletion potential and thus conformed to the Montreal Protocol regulation. It requires Polyol ester oil (POE) oil for its compressor's lubricant. Its refrigerant capacity and performance are about the same as the refrigerant R22.
- POE or PVE oil is used as lubricant for R407C compressor, which is different from the mineral oil used for R22 compressor. During installation or servicing, extra precaution must be taken not to expose the R407C system too long to moist air. Residual POE or PVE oil in the piping and components can absorb moisture from the air.
- Refrigerant R407C is more easily affected by dust or moisture compared with R22, make sure to temporarily cover the ends of the tubing prior to installation.
- No additional charge of compressor oil is permitted.
- No other refrigerant other than R407C.
- Tools specifically for R407C only (must not be used for R22 or other refrigerant)
 - i) Manifold gauge and charging hose
 - ii) Gas leak detector
 - iii) Refrigerant cylinder/charging cylinder
 - iv) Vacuum pump c/w adapter
 - v) Flare tools
 - vi) Refrigerant recovery machine
- Filter-dryer must be installed along the liquid line for all R407C air conditioners. This is to minimise the contamination of moisture and dirt in the refrigerant system. Filter-dryer must be of molecular sieve type. For a heat-pump system, install a two-way flow filter dryer along the liquid line.

VACUUMING AND CHARGING

Vacuumping is necessary to eliminate all moisture and air from the system. The series II Outdoor Unit is provided with flare valve fittings.

Vacuumping The Piping And The Indoor Unit

Except for the outdoor unit which is pre-charged with refrigerant, the indoor unit and the refrigerant connection pipes must be air-purged because the air containing moisture that remains in the refrigerant cycle may cause malfunction of the compressor.

- Remove the caps from the valve and the service port.
- Connect the center of the charging gauge to the vacuum pump.
- Connect the charging gauge to the service port of the 3-way valve.
- Start the vacuum pump. Evacuate for approximately 30 minutes. The evacuation time varies with different vacuum pump capacity. Confirm that the charging gauge needle has moved towards -760mmHg .

Caution

- If the gauge needle does not move to -760mmHg , be sure to check for gas leaks (using the refrigerant detector) at flare type connection of the indoor and outdoor unit and repair the leak before proceeding to the next step.
- Close the valve of the charging gauge and stop the vacuum pump.
- On the outdoor unit, open the suction valve (3 way) and liquid valve (2 way) (in anti-clockwise direction) with 4mm key for hexagon sacked screw.

Charge Operation

This operation must be done by using a gas cylinder and a precise weighing machine. The additional charge is topped-up into the outdoor unit using the suction valve via the service port.

- Remove the service port cap.
- Connect the low pressure side of the charging gauge to the suction service port center of the cylinder tank and close the high pressure side of the gauge. Purge the air from the service hose.
- Start the air conditioner unit.
- Open the gas cylinder and low pressure charging valve.
- When the required refrigerant quantity is pumped into the unit, close the low pressure side and the gas cylinder valve.
- Disconnect the service hose from service port. Put back the service port cap.

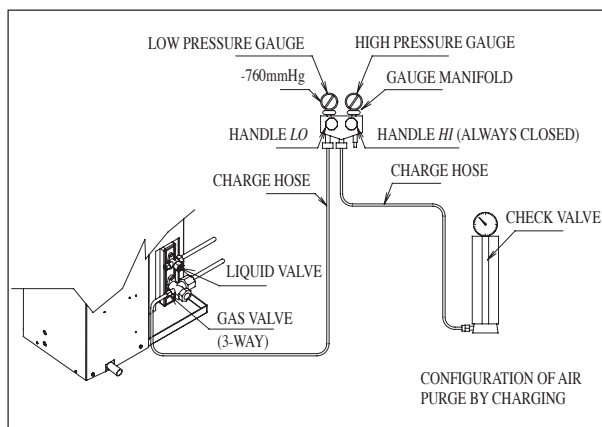
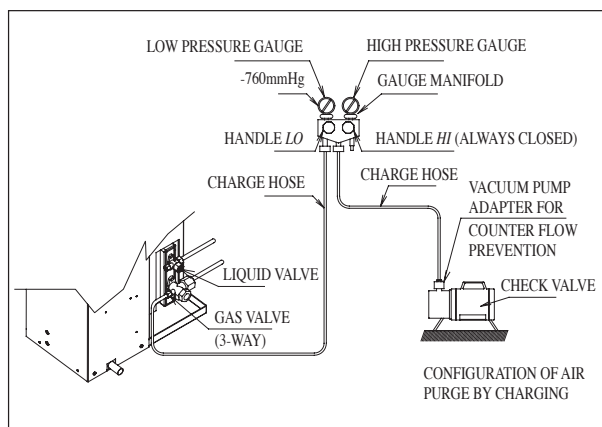
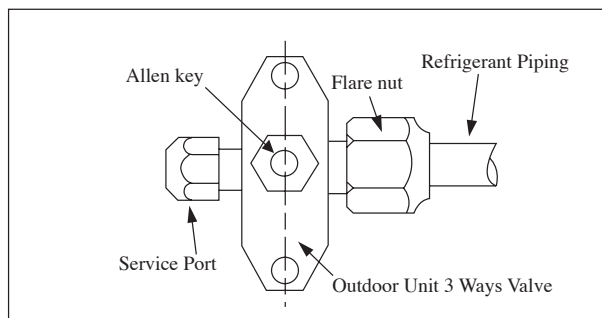

⚠ CAUTION

- R407C must be charged as liquid. Usually R407C cylinder is equipped with a dip-pipe for liquid withdrawal. If there is no dip-pipe, the cylinder should be inverted so as to withdraw liquid R407C from the valve.
- Do not top-up when servicing leak, as this will reduce the unit performance. Vacuum the unit thoroughly and then charge the unit with fresh R407C according to the amount recommended in the specification.

ADDITIONAL CHARGE

The refrigerant is pre-charge in the outdoor unit. If the piping length is less than 7.5m, then additional charge after vacuuming is not necessary. When the piping length is more than 7.5m, use the table below.

	R22	R407C
Liquid pipe OD	Additional charge kg/m	Additional charge kg/m
3/8"	0.06	0.05
1/2"	0.10	0.10
5/8"	0.16	0.15
3/4"	0.25	0.23

NOTE

The additional refrigerant charge amount recommended is a guideline for long piping application. The actual charge required may be different from the guideline due to different application and variation in site conditions.

SPECIAL PRECAUTIONS WHEN CHARGING UNIT WITH SCROLL COMPRESSORS

These precautions are intended for use with Scroll compressors only with R22 and R407C refrigerants but are not applied to others competitive Scroll compressors.

Scroll compressors have a very high volumetric efficiency and quickly pump a deep vacuum if there is insufficient refrigerant in the system or if refrigerant is added too slowly. Operation with low suction pressure will quickly lead to very high discharge temperatures. While this process is happening, the scrolls are not being well lubricated – scrolls depend on the oil mist in the refrigerant for lubrication. A lack of lubrication leads to high friction between the scroll flanks and tips and generates additional heat. The combination of heat of compression and heat from increased friction is concentrated in a small localized discharge area where temperatures can quickly rise to more than 300°C. These extreme temperatures damage the Scroll spirals and the orbiting Scroll bearing. This damage can occur in less than one minute especially on larger compressors. Failure may occur in the first few hours or the damage done during field charging may show up some time later. Other typical field charging problems include undercharging, overcharging, moisture or air in the system etc. In time each one of these problems can cause compressor failure.

Minimal equipment is required for field charging. The minimum equipment required to do a satisfactory job is:-

- | | |
|--------------------------|-----------------|
| 1. Set of service gauges | 4. Vacuum gauge |
| 2. Hoses | 5. Scales |
| 3. Vacuum pump | 6. Thermometer |

The proper refrigerant charge should follow the volume as recommended by manufacturer and recommendation should be followed by the installer.

1. Charging procedures – Single phase compressors

Evacuate the system to -760mmHg. To reduce evacuation time, use short, large diameter hoses and connect to unrestricted service ports on the system. Quality of vacuum cannot be determined by time – a reliable vacuum gauge must be used. (etc. electronic vacuum gauge)

Turn the refrigerant cylinder upside down, purge the charging hose and charge liquid through the liquid line charging port until refrigerant no longer flows or until the correct charge has been weighed in. If additional charge is required start the system and slowly bleed liquid into the suction side until the system is full.

It recommends charging liquid in a CONTROLLED manner into the suction side until the system is full.

This recommendation does not hold true for reciprocating compressors where liquid charging into the suction side could cause severe damage.

Carefully monitor the suction and discharge pressures – ensure that the suction pressure does not fall below 25 psig (1.7 bar) at any time during the charging process.

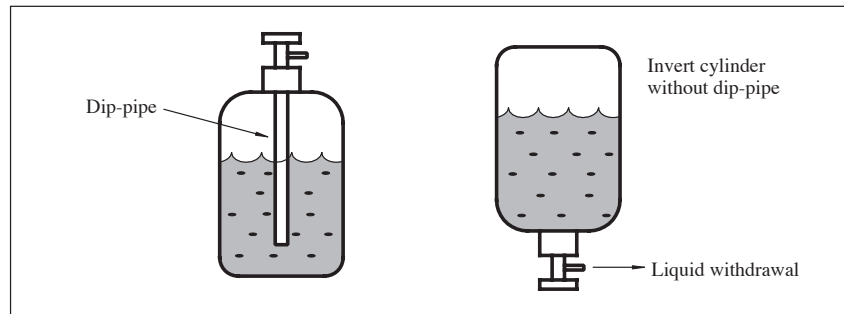

⚠ CAUTION

- Manifold Gauge will show cylinder pressure rather than suction pressure if the cylinder valve and Manifold valve “A” are both open.

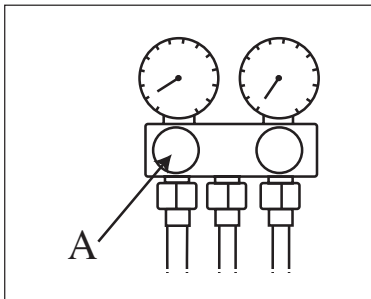

There are many ways of charging liquid in a “controlled manner” into the suction side:-

1. Use valve A on the manifold gauge set
2. Use the valve on the refrigerant cylinder
3. Charge through a Shredder valve
4. Use a hose with a Shredder valve depressor
5. Charge into the suction side at some distance from the compressor
6. All of the above

2. Charging procedures – Three phase compressors

The fundamental procedure is the same as for single phase models but the compressor can run in the wrong direction on starting. If this happens reverse any two phases and start again. Short term reverse rotation will not damage the compressor. All Specter compressors have internal discharge temperature protectors which are very effective in preventing dangerously high discharge temperatures during charging. The protection module will trip and lock the compressor out for 30 minutes. It is not normally necessary to wait 30 minutes for the module to reset. When the compressor has cooled down the module can be reset by breaking the power supply to the control circuit. Very often the serviceman does not understand why the module tripped and uses a jumper wire to bypass it. He continues to charge the system and removes the jumper when charging is complete. The compressor may or may not run with the protector back in the circuit but it is certain that the compressor has been damaged and premature failure is inevitable.

STANDARD OPERATING CONDITIONS

Cooling

Temperature	Ts °C	Th °C
Minimum indoor temperature	16	11
Maximum indoor temperature	32	23
Minimum outdoor temperature	16	11
Maximum outdoor temperature	46	24

Heating

Temperature	Ts °C	Th °C
Minimum indoor temperature	16	-
Maximum indoor temperature	30	-
Minimum outdoor temperature	-5	-6
Maximum outdoor temperature	24	18

Ts: Dry bulb temperature. Th: Wet bulb temperature.

PHASE PROTECTOR (OPTIONAL)

The unit with Scroll Compressor can only rotate in one direction. For this reason, a protective device (phase protector) is fitted to prevent incorrect wiring of the electrical phases. When the three phases are not connected correctly, the phase sequencer operates, and the unit will not start. This device is located in the control box of the outdoor unit.

The following table shows the LED indicator light for phase protector under normal operation and fault conditions.

Description	LED	PW (Red)	P_R (Yellow)	P_S (Yellow)	P_T (Yellow)	Actions
Normal operation		○	●	●	●	-
Reverse phase		◐	◐	◐	◐	Switch off the unit. Check the 3 phase wiring.
T phase missing		◐	●	●	◐	Switch off the unit. Check the 3 phase wiring.
S phase missing		◐	●	◐	●	Switch off the unit. Check the 3 phase wiring.
R phase missing		●	●	●	●	Switch off the unit. Check the 3 phase wiring.
S & T phase missing ⁺		◐	●	◐	◐	Switch off the unit. Check the 3 phase wiring.
Overload ⁺		◐	●	●	●	High discharge temperature. Check the refrigerant system.
Sensor missing ⁺		◐	○	○	○	Switch off the unit. Plug in sensor.

○ ON

● OFF

◐ Fast Blink

NOTES

1. “+” indicates additional functions for PP01 phase protector.
2. When R phase missing, no LED or buzzer will indicate the error, but relay 71 and relay 81 will cut off.

⚠ **WARNING**

- Troubleshooting must be performed by qualified personnel.

SERVICE AND MAINTENANCE

Service Parts	Maintenance Procedures	Period
Indoor air filter	<ol style="list-style-type: none"> 1. Remove any dust adhering to the filter by using a vacuum cleaner or wash in lukewarm water (below 40°C) with a neutral cleaning detergent. 2. Rinse the filter well and dry before placing it back onto the unit. 3. Do not use gasoline, volatile substances or chemicals to clean the filter. 	<p>At least once every 2 weeks.</p> <p>More frequently if necessary.</p>
Indoor unit	<ol style="list-style-type: none"> 1. Clean any dirt or dust on the grille or panel by wiping it with a soft cloth soaked in lukewarm water (below 40°C) and a neutral detergent solution. 2. Do not use gasoline, volatile substances or chemicals to clean the indoor unit. 	<p>At least once every 2 weeks.</p> <p>More frequently if necessary.</p>
Indoor Fan	<ol style="list-style-type: none"> 1. Check for any abnormal noise. 	When necessary.

⚠ CAUTION

Do not operate any heating apparatus too close to the air conditioner unit. This may cause the plastic panel to melt or deform as a result of the excessive heat.

TROUBLESHOOTING

For any enquiries on spare parts, please contact your authorized dealer. When any malfunction of the air conditioner unit is noted, immediately switch off the power supply to the unit. Check the following fault conditions and causes for some simple troubleshooting tips.

Fault	Causes / Action
1. The compressor does not operate 3 minutes after the air conditioner unit is started.	– Protection against frequent starting. Wait for 3 to 4 minutes for the compressor to start operating.
2. The air conditioner unit does not operate.	<ul style="list-style-type: none"> – Power failure, or the fuse needs to be replaced. – The power plug is disconnected. – It is possible that your delay timer has been set incorrectly.
3. The airflow is too low.	<ul style="list-style-type: none"> – The air filter is dirty. – The air suction and discharge are clogged. – The regulated temperature is not high enough. (applicable for auto-fan mode only)
4. Discharge airflow has bad odor.	– Odors may be caused by cigarettes, smoke particles, perfume etc. Which might have adhered onto the coil.
5. Condensation on the front air grille of the indoor unit.	<ul style="list-style-type: none"> – This is caused by air humidity after an extended long period of operation. – The set temperature is too low, increase the temperature setting and operate the unit at high fan speed.
6. Water flowing out from the air conditioner unit.	– Switch off unit and call local dealer / serviceman.

If the fault persists, please call your local dealer / serviceman.

MEMO



- In the event that there is any conflict in the interpretation of this manual and any translation of the same in any language, the English version of this manual shall prevail.
- The manufacturer reserves the right to revise any of the specification and design contain herein at any time without prior notification.
- En cas de désaccord sur l'interprétation de ce manuel ou une de ses traductions, la version anglaise fera autorité.
- Le fabriquant se réserve le droit de modifier à tout moment et sans préavis la conception et les caractéristiques techniques des appareils présentés dans ce manuel.
- Im Falle einer widersprüchlichen Auslegung der vorliegenden Anleitung bzw. einer ihrer Übersetzungen gilt die Ausführung in Englisch.
- Änderungen von Design und technischen Merkmalen der in dieser Anleitung beschriebenen Geräte bleiben dem Hersteller jederzeit vorbehalten.
- Nel caso ci fossero conflitti nell'interpretazione di questo manuale o delle sue stesse traduzioni in altre lingue, la versione in lingua inglese prevale.
- Il fabbricante mantiene il diritto di cambiare qualsiasi specificazione e disegno contenuti qui senza precedente notifica.
- En caso de conflicto en la interpretación de este manual, y en su traducción a cualquier idioma, prevalecerá la versión inglesa.
- El fabricante se reserva el derecho a modificar cualquiera de las especificaciones y diseños contenidos en el presente manual en cualquier momento y sin notificación previa.
- В случае противоречия перевода данного руководства с другими переводами одного и того же текста, английский вариант рассматривается как приоритетный.
- Завод-изготовитель оставляет за собой право изменять характеристики и конструкцию в любое время без предварительного уведомления.
- Bu kılavuzun anlaşılmasında bir çatışma olduğunda ve farklı dillerdeki tercümele farklılık gösterdiğinde, bu kılavuzun İngilizce sürümü üstün tutulacaktır.
- Üretici burada bulunan herhangi teknik özellikleri ve tasarımları herhangi bir zamanda ve önceden haber vermeden değiştirme hakkını saklı tutar.

DAIKIN EUROPE N.V.
Zandvoordestraat 300, B-8400 Oostende, Belgium

DAIKIN MCQUAY MIDDLE EAST FZE
P.O.Box 18674, Galleries 4, 11th Floor,
Downtown Jebel Ali, Dubai, UAE.

Importer for Turkey:
DAIKIN ISITMA VE SOĞUTMA SİSTEMLERİ
SANAYİ TİCARET A.Ş.
Hürriyet Mah. E-5 Yan Yol Üzeri No:57/2
34876 Kartal – İstanbul Türkiye