



HAND BLENDER XM-31

Professional immersion blender. 400 W.



- ✓ Professional performance: capable of carrying out prolonged work without the casing overheating.
- ✓ Life-plus: equipped with a motor which has passed all of the most demanding usage tests.
- ✓ Studied geometry: casing designed to avoid rolling and falling.
- ✓ Easy to clean: detachable arm, can be cleaned under the tap.
- ✓ Approved by NSF: guaranteed safety and hygiene.

INCLUDES

- ✓ Fixed speed motor block.
- ✓ MA-31 mixer arm.
- ✓ Wall mount.

ACCESSORIES

- Clamp sliding frame
- Bowl clamp
- Mixer arms MA-30

SALES DESCRIPTION

Fixed speed motor block.
306 mm detachable arm.
Designed for continuous use in recipients of up to 30 litres.

All-in-one

- ✓ Professional hand blender designed for carrying out different preparations without the need for add-on tools.
- ✓ Professional Y-blade, made from tempered steel and with a long-duration cutting edge.
- ✓ Fixed speed.
- ✓ Designed to work in recipients of up to 30 litres.

Maximum comfort for the user

- ✓ Compact design: logical and manageable size.
- ✓ Ergo-design & bi-mat-grip: external casing made in two materials for an ergonomic hold. Anti-slip grip. Optimum inclination of handle, minimising fatigue.
- ✓ Click-on-arm: detachable arm with fast and secure closure.
- ✓ Hood designed to avoid splashes.
- ✓ Intuitive use: very simple operation. LED warning light in two colours to indicate the status of the machine.
- ✓ Possibility of continuous operation.

Built to last



sammic | www.sammic.com
Food Service Equipment Manufacturer

Polígono Basarte, 1. phone +34 943 15 72 36
20720 Azkoitia, Spain sales@sammic.com



Project	Date
Item	Qty
Approved	

DYNAMIC PREPARATION
COMMERCIAL HAND BLENDERS - XM RANGE

product sheet
updated 29/03/2021



HAND BLENDER XM-31

Professional immersion blender. 400 W.



SPECIFICATIONS

Total loading: 400 W
Maximum recipient capacity: 30 l
Maximum working depth: 207.3 mm
Motor speed: 12000 rpm
Blade diameter: 55 mm
Blade guard diameter: 92.2 mm

Length

Liquidising arm length: 306 mm
Total length: 614 mm

Net weight: 3.34 Kg
Noise level (1m.): <80 dB(A)

Motor speed: 12000 rpm
Blade diameter: 55 mm
Blade guard diameter: 92.2 mm

Length

Liquidising arm length: 306 mm
Total length: 614 mm

Net weight: 3.34 Kg
Noise level (1m.): <80 dB(A)

Crated dimensions

455 x 475 x 117 mm
Gross weight: 4.2 Kg.

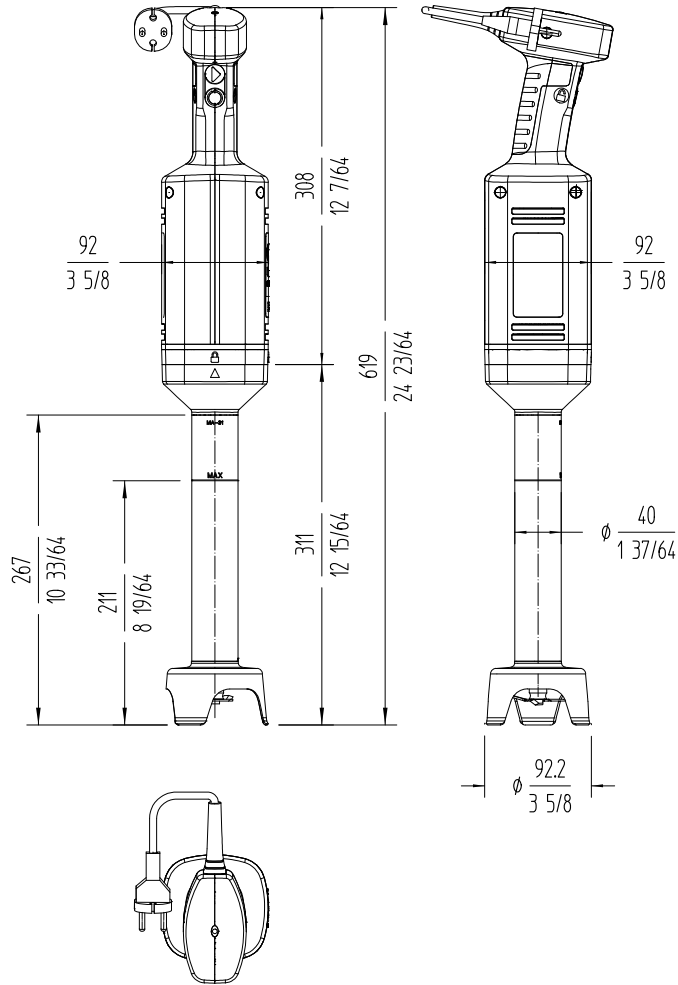

DYNAMIC PREPARATION
COMMERCIAL HAND BLENDERS - XM RANGE

AVAILABLE MODELS

3030672 Immersion blender XM-31 230/50-60/1

* Ask for special versions availability

sammic | www.sammic.com
Food Service Equipment Manufacturer

Polígono Basarte, 1. phone +34 943 15 72 36
20720 Azkoitia, Spain sales@sammic.com



Project	Date
Item	Qty
Approved	

product sheet
updated 29/03/2021